



УДК 628.5

**APPLICATION OF THE LAGRANGE METHODS FOR OPTIMIZATION OF INTERACTION IN AQUATIC SYSTEMS****ЗАСТОСУВАННЯ МЕТОДІВ ЛАГРАНЖА ДЛЯ ОПТИМІЗАЦІЇ ВЗАЄМОДІЇ У ВОДНИХ СИСТЕМАХ****Shandyba A.V. / Шандиба О.В.***Ph.D, as. prof. / к.т.н., доц.***Tolbatov A.V. / Толбатов А.В.***Ph.D, as. prof. / к.т.н., доц.***Smolarov G.A. / Смоляров Г.А.***Ph.D, as. prof. / к.е.н., доц.**Sumy National Agrarian University, Sumy, Kondrat'eva St. 160, 40021*

**Abstract:** *This project embraces the recycling water supply systems and relates to rational use of clean water as well as to improving wastewater and sludges treatment. The optimization problem is that the recycling water supply has to be a complex system of individual tools should be an effective part of it. To except blowing the different intensity of contaminants accumulation in such systems must be compensated by means of the adequate intensity of contaminants removing. The second area of application regarding to the research and development of the hydrodynamic Lagrange method jointly with the boundary streams model for calculation of power interaction between water flow and streamlining units used for the exploitation of offshore deposits.*

**Key words:** *Lagrange method, aquatic systems, waste heat utilization plant, power interaction, head-resistance, hydraulic loss coefficients, ring contraction.*

**Introduction.** It is evident that hydraulic one-dimension method based on the average flow velocity brings to the unsusceptible model for aquatic systems optimization. According to the widespread hydrodynamic Euler method we should study a velocity field connected with the local velocity concept under solving the Navier-Stokes equations (Atanov, Daugherty 1985). To the contrary, the Lagrange method deals with the individual water particles and it seems to be more natural approach. However, for unknown flow lines this method has not the advantage by mathematical difficulties. Nevertheless, we have the row of engineering problems characterized with the quite defined boundary and initial conditions regarding to the some particular elements of flow (Daily & Harleman 1971, Wirz & Smolderen 1978). For example, the boundary streams move along the flow formative lines and it is the important circumstance to use the Lagrange method for calculation of interactions between flow and streamlining bodies (Shandyba et al.1992, 1998, 1999 ). On the other hand, filtration moving along relief slope allows to solve the mass-transfer equations and predict the ecology consequences of chemical substances migration (including radionucleades) into ground water and the residue levels of the dangerous chemicals in soil (Shandyba et al. 1997). This simple and comprehensive method also can be used to improve the design and operation of recycling water treatment of manufacturing process systems (USSR Patent No 1761819). At the same time, there is growing technical concern about the available optimization procedures which take into account the easy-defined integral parameters of hydrodynamic, chemical or biology interactions in different aquatic systems. On this reason, an attempt is made up for an extension of this field [1, 2, 3, 4, 5, 6, 7, 8, 9, 10, 11, 12, 13, 14, 15].



**Differential recycling water supply system.** The use of recycling water supply systems under non-blowing operation results in the contaminants accumulation and exceeding concentration limits for circulation water (Shandyba 1996, Ukraine Patent No 20947 A). Balance of accumulation and contaminant removing is provided by treatment plants (cleaners) which usually are special-purposed for several contaminants (Fig. 1). However, it is necessary to remove all dangerous limited components from circulation water. Moreover, a different intensity of a different contaminants accumulation in circulation water must be compensated by means of an adequate intensity of removing these components from water on the treatment stages. To prevent exceeding of the allowable level of the contaminant concentration in circulation water the following condition should be provided:

$$C'_i E_i Q + C_i E_{ip} Q_p = (r + g) C_{io} + M_i - G_i \tag{1}$$

where  $C'_i$  - limit concentration of  $i$  contaminant in circulation water;  $C_i$  - actual concentration of  $i$  contaminant in circulation water;  $C_{io}$  - initial concentration of  $i$  contaminant in fresh water;  $E_i$  - removing efficiency on the cleaning plant;  $E_{ip}$  - removing efficiency of  $i$  contaminant on the bypass cleaning plant;  $Q$  - circulation water rate;  $Q_p$  - bypass water rate;  $M_i$ ;  $G_i$  - accumulation and loss intensity of  $i$  contaminant;  $(r + g)$  - evaporation and hydraulic transfer rate.

To realize the suggested approach in practice we have proposed the two-staged waste heat utilization plant (figure 2 ). The operation is possible if the intensity of hardness accumulation in water does not exceed some level determined eq.(1) under efficiency corresponding to the heat output of flue gas flow (Ukraine Patent No 20947 A). Evidently, if the heat output is not sufficient for heating the whole circulation water rate, then it can be enough for heating bypass water. The sample of heat utilization plant made as a scrubber 1 with flue gas inlet 2 and outlet 3, sprayers 4, drop separator 5 settling cone 6. Besides the system includes heat exchanger 7, circulation pump 8, neutralizer 9 and stabilizer 10.

Under operation, the flue gas through the inlet 2 flows into the scrubber 1, heats the sprayed circulating water to 55-65°C and arises with the captured water drops to the drop separator 5. After the separation, a some part of the circulating water passes through the heat exchanger 7 to the neutralizer 9. The lime slurry neutralization of high temperature water brings to more hardness reducing and water stabilization.

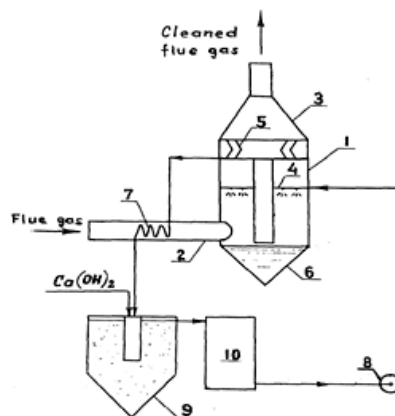

**Fig. 1. Differential recycling water supply system**

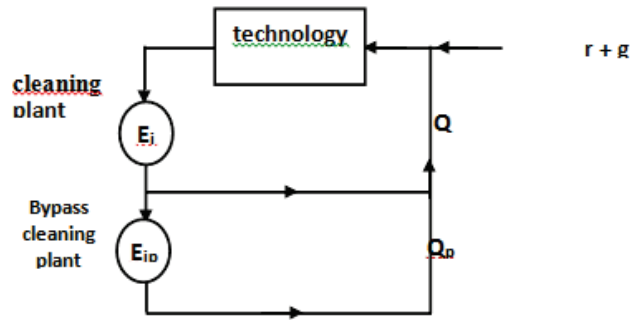
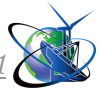
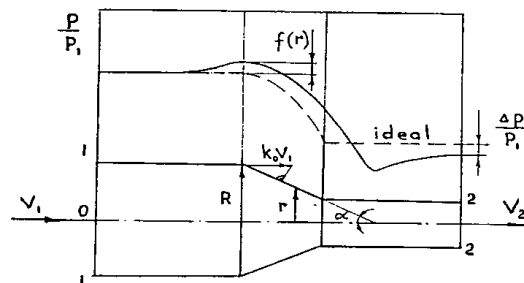

**Fig. 2. Flue gas heat utilization plant**

**Power interaction in water flow. Theory of head-resistance under contraction.** The conical contraction is the most widespread unit of many technical systems. For the inside problem of Hydrodynamics it is the noticeable sample of power interaction between flow and streamlining surface (Daily & Harleman 1971, Shandyba 1992, 1999). In this consideration we shall be limited by the developed turbulence regime that allows to examine the influence of contraction geometry on pressure distribution, energy losses and drag resistance. It was found that the loss of pressure in axially symmetric conical contraction (fig. 3) is connected with the excess pressure of viscous flow to ideal flow by the following

$$\text{equation: } \Delta p S_2 = 2\pi \int_r^R f(r) r dr \tag{3.1}$$

where  $\Delta p$  is loss of pressure,  $S_2$  is lesser cross-sectional area,  $r$ ,  $R$  are radiuses lesser and greater cross sections,  $f(r)$  is excess pressure of viscous flow to ideal flow.



**Fig. 3. Excess pressure of viscous flow to Ideal flow**

To determinate this function  $f(r)$  we suppose the whole flow in the contraction as the complex of elementary streams where pressure and velocity are averaged on time according to the Reynolds-Boussinesque model [1, 3, 11, 13, 14, 15]. Taking into account the change of the flow structure in contraction, one must consider the two characteristic sections of flow: before and into contraction. The character of interacting each stream with the conical surface depends on its initial disposition in flow before contraction and the contraction geometry. At this point of view the boundary streams seem to be most important. Under the unseparated streamlining movement these have the quite defined ways like the contraction formative lines. Using the impulse conservation equation the excess pressure can be



found for the boundary streams. Thus, if a liquid particle with mass equal  $\rho$  has the impuls  $\rho(k_0 V_1)$  in cross-section 1-1 (where  $k_0$  is ratio of boundary stream velocity to average flow velocity before contraction), then its impuls will be equal  $\rho(k_0 V_1)\cos\alpha$  after interacting with the conical surface under attack angle  $\alpha$ .

The corresponding excess pressure in the connection point of conical contraction will be defined from Bernoulli's equation:

$$p(R) = p_1 + \frac{\rho(k_0 V_1)^2}{2} - \frac{\rho(k_0 V_1)^2}{2} \cos^2 \alpha = \tag{3.2}$$

$$= p_1 + \frac{\rho(k_0 V_1)^2}{2} \sin^2 \alpha$$

where excess pressure function  $f(R) = \frac{\rho(k_0 V_1)^2}{2} \sin^2 \alpha$

The experimental data confirm the presence and proportionality of the excess pressure to  $\sin^2 \alpha$  function. It is important to note the increasing of excess pressure along the boundary streams on any head streamlininig surface under contraction of flow. This takes place because there is energy redistribution in contraction connected with increasing energy of the boundary streams accordingly decreasing energy of the inside streams. The corresponding excess pressure occurs due to the change of impulses of the inside streams. The value of pressure change may be found from the following arguments. First, the excess pressure of real flow to ideal flow is the result of the interaction between flow and inside surface of contraction. It is connected with the changes of velocities and, accordingly, liquid particles' impulses in the streams. Moreover, only a part of impulse's energy is consumed for increasing potential energy of the boundary streams. This increasing conforms to  $\sin^2 \alpha$  function. From the impulse conservation we can see that interaction of the inside streams with the contraction surface will be analogous with the boundary streams' interaction under their turning. In other words, a ratio of excess potential  $f$  and kinetic  $\phi$  energy is kept constantly on all inside surface of

the conical contraction, i.e., if  $\alpha = const$ ,

$$\frac{df(r)}{d\phi(r)} = \frac{\sin^2 \alpha}{\cos^2 \alpha} = const \tag{3.3}$$

Generally speaking, the distribution of the excess energy in the boundary streams depends on the initial impulses distribution in flow and the local angles of interaction with the contraction surface. The excess energy distribution can be expressed as the sum:  $dE = df(r) + d\phi(r) = dE \sin^2 \alpha + dE \cos^2 \alpha$  (3.4)

Second, the velocity of considering streams will increase in accordance with reduction of cross-sections of the contraction as well as the excess pressure will increase proportionally to the contraction degree function  $s = R^2 / r^2$ . It is very essential that the summary increase of kinetic energy of the boundary streams consists of the ideal and impulse components. The impulse component is increased by energy reduction of the inside streams having the liquid particles with  $\rho k V_1$  impulses, where  $k$  function increases from  $k_0$  to  $k_{max}$  for axis.

At the same time the ideal component is increased by Bernoulli's equation and correlated to  $s^2$  function in accordance with the continuous equation. On the same reason, the summary increase of kinetic energy of the boundary streams also is



correlated to this contraction degree function.

Evidently, the impulse kinetic component  $d\phi(r)$  is changed as the difference in analogous way:  $d\phi(r) = \frac{\rho(kV_1)^2}{2} \cos^2 \alpha d(s^2)$  (3.5)

Therefore, from eq. (4) the excess pressure will depend on this function too:

$$df(r) = \frac{\rho(kV_1)^2}{2} \sin^2 \alpha d(s^2) \quad (3.6)$$

As integral, the excess pressure distribution on inside surface of contraction is:

$$f(r) = \frac{\rho V_1^2}{2} \int_1^s k^2 \sin^2 \alpha d(s^2) + f(R) \quad (3.7)$$

Then the shape component of head-resistance force can be defined as:

$$\Delta p S_2 = 2\pi \int_0^r \left[ \frac{\rho V_1^2}{2} \int_1^s k^2 \sin^2 \alpha d(s^2) + f(R) \right] r dr \quad (3.8)$$

**Axially symmetric model.** For a passage to the external aerodynamic problem [1, 3, 4, 8 11, 13, 14, 15] we shall consider the peculiar ring contraction at the head of streamlining pontoon (fig. 4), In this case we have a cylindrical long body with conical head situated in tube. Obviously, the hydraulic losses coefficient of the whole body may be presented as the sum:

$$\xi_x = \xi_h + \xi_r + \xi_s \quad (3.9)$$

where  $\xi_h$ ,  $\xi_r$ ,  $\xi_s$  are the hydraulic loss coefficients of the ring contraction, pontoon surface friction and Borda's sudden expansion after stern.

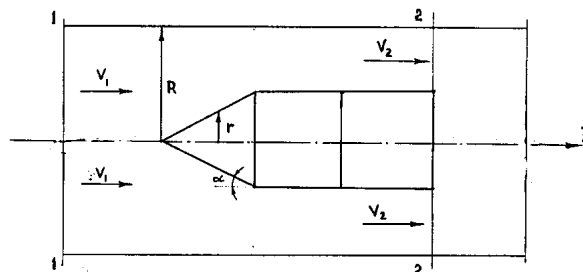

**Fig. 4. Ring contraction at the conical head of pontoon**

Assuming  $\alpha = \text{const}$ ,  $k=1$  after integrating and transformation (3.8) we obtain:

$$\Delta p = \xi_h \frac{\rho V_1^2}{2} = (1/n^2 - 1/n) \sin^2 \alpha \frac{\rho V_1^2}{2} \quad (3.10)$$

where  $n = 1 - r^2 / R^2$ .

From Borda's formula :  $\Delta p = \xi_s \frac{\rho V_1^2}{2} = \frac{(1-n)^2}{n^2} \frac{\rho V_1^2}{2}$  (3.11)

The share of these components can be calculated on the analogy of pipelines. As result, the total hydrodynamic resistance of pontoon under disregarding friction is:

$$F_x = \frac{\pi R^2}{n^2} \left[ (1-n) \sin^2 \alpha + (1-n)^2 \right] \frac{\rho V^2}{2} \quad (3.12)$$

where contraction degree  $n = 0.695$  for free flow.

It is important to note that there is a possibility to optimize the power interaction



by improving shape of streamlining bodies (Shandyba&Nazarenko 1998).

**Concluding remarks.** The specimen results shown in the present report concern mainly water flows but may be used for optimization procedures in air protection plant. The Lagrange methods are the good means for calculation of the optimal hydraulic and mass-transfer regimes as well as for improving process design.

The effective management of hydraulic regimes, through improved system operation or new technology, leads to the more efficient use and conservation of resources and energy.

### References

1. Tolbatov A. Mathematical models for the distribution of functions between the operators of the computer-integrated flexible manufacturing systems / Lavrov E., Pasko N., Krivodub A., Tolbatov A. / 2016 Modern Problems of Radio Engineering, Telecommunications and Computer Science, Proceedings of the 13th International Conference on TCSET 2016 – Lviv-Slavske, 2016. – P. 72–75.
2. Daily J.&Harleman D. 1971. *Fluid Mechanics* (tr.from English), Energy Publ. Corp.
3. Tolbatov A. Data representing and processing in expert information system of professional activity analysis / Zaritskiy, O., Pavlenko, P., Tolbatov, A. / 2016 Modern Problems of Radio Engineering, Telecommunications and Computer Science, Proceedings of the 13th International Conference on TCSET 2016 – Lviv-Slavske, 2016. – P. 831–833.
4. Shandyba A.B. 1992. *Hydraulic resistance of conical contraction*. in Collect. of articles on Chemical Mashine-Building. TMK Publ.: Kiev, pp.89-94.
5. Shandyba A.B., Filonov A.P. & Gontar I.V. 1996. *The differential wastewater treatment in the circulation systems*. Journal of Chemical Industry of Ukraine. Kiev, vol.5, P. 35-37.
6. Shandyba A.B., Vacal S.V. & Chivanov V.D. 1997. *Pollution removing by washing of contaminated soils*. Proc. of the GREEN-2 Simposium.: Krakow, Poland.
7. Shandyba A.B. & Nazarenko A.M.1998. *Optimization of the head surface configuration of bridge supports*. Journal of Mechanical Engineering, vol.2, Sumy State University Publishing: Sumy, pp. 322-325.
8. Shandyba A.B. 1999. *Lagrange method in Irrigation System Hydraulics*. Journal of Mechanical Engineering, vol.4, Sumy State University Publ.: Sumy, pp. 146-150.
9. Ukraine Patent No 20947 A, B 01 D47/00. 1993. *Method of circulation water treatment for waste heat utilization plants*.
10. USSR Patent No 1761819, C 23 C3/02. 1992. *Device for liquid treatment of wire*.
11. Tolbatov A. Theoretical bases, methods and technologies of development of the professional activity analytical estimation intellectual systems / Zaritskry, O., Pavlenko, P., Sudic, V., Tolbatov, A., Tolbatova, O., Tolbatov, V., Viunenko, O. / 2017 2nd International Conference on Advanced Information and Communication Technologies, AICT 2017 – Proceedings – Lviv, 2017. – P. 101–104.
12. A.B. Shandyba, D.M. Shpetny. 2015. Pollution migration forecast for soil geochemistry mapping. - Geomatics, Landmanagement and Landscape. No. 3 • 2015, 101–112.
13. Tolbatov A.V. Functional modeling – methodological basis for investigation of business processes at industrial enterprises / A.V. Tolbatov, S.V. Tolbatov, O.O. Tolbatova, S.V. V.A. Tolbatov // International scientific-technical magazine Measuring and computing devices in technological processes. – Khmel'nyts'ky, 2017. – №3 –P. 186–189.
14. Tolbatov A.V. Business processes management at machine-building enterprise / A.V. Tolbatov, O.O. Tolbatova, I.A. Shekhovtsova, V.A. Tolbatov // International scientific-technical magazine Measuring and computing devices in technological processes. – Khmel'nyts'ky, 2017. – №4 –P. 119–124.
15. Tolbatov A.V. Information technology for data exchange between production purpose integrated automated systems / P.M. Pavlenko, A.V. Tolbatov, V.V. Tretiak, S.V. Tolbatov, V.A.



Tolbatov, H.A. Smolyarov, O.B. Viunetko // International scientific-technical magazine Measuring and computing devices in technological processes. – Khmel'nyts'kyu, 2016. – №1 –P. 86–89.

**Анотація:** В статті розглядаються оборотні системи водопостачання з точки зору раціонального використання води і комплексної обробки осадів. Оптимізаційна проблема стосується ряду окремих елементів, що повинні функціонувати, як ефективні частини подібних систем. Щоб зменшити або виключити процес продування забруднень, які накопичуються в системах з диференційованою інтенсивністю, необхідно компенсувати їх адекватним видаленням. Іншою областю застосування гідродинамічного методу Лагранжа є модель межових струменів, що дозволяє розрахувати силову взаємодію обтікаючого потоку з елементами руслових споруд.

**Ключові слова:** Метод Лагранжа, водні системи, установка утилізації тепла, силова взаємодія, лобовий опір, коефіцієнти гідравлічних втрат, кільцеве стиснення.