

The Wall Temperature Measurement and Effects on the Missile Complex Surface Based on the Semiconductor Diode and Electronic System

A. M. Pavliuchenko, O. M. Shyiko, T. I. Klochkova

Sumy National Agrarian University, 160 Herasym Kondratiev Street, Sumy, 40021, Ukraine

The problem of high-precision measurement of the temperature of the forebody wall of an aerophysical missile complex in flight along the trajectory to the altitude of $H \leq 8$ km in response to changes in the numbers of Mach $M_\infty \leq 2.0$, Reynolds $Re_{L,\infty} \leq 2 \cdot 10^7$, non-isothermicity, solid-fuel jet engine (SFJE) operation with acceleration of $a \leq 12g$ that are not simultaneously simulated in modern supersonic aerodynamic units, has been solved. Semiconductor diodes CD-521 from different materials have been used to measure the temperature of the wall of this object along the forebody length. The sensitivity of CD-521 is 2.5 mV/deg. The airborne electronic and telemetry systems have a high degree of accuracy and high-speed action. The survey of semiconductor diodes CD-521 has been carried out consistently in time at intervals of 5ms, and the error of measurement of the temperature of the forebody wall of the missile aerophysical complex does not exceed 1%. The airborne electronic and telemetry systems, semiconductor diodes CD-521 and data on the wall temperature along the forebody length have enabled to resolve aerophysical challenges associated with the supersonic separated and unseparated flow of the missile complex forebody under the laminar-turbulent transition in the wall jet and in its interaction with the separated wall flow.

Keywords: aerophysical missile complex, complex forebody, wall temperature, semiconductor diode, airborne electronic system, telemetry, supersonic separated and unseparated wall flow, laminar-turbulent transition in the wall jet, heat flux, local peaks of the wall temperature and heat flux.

DOI:

PACS number(s): 47.85.Gj

1. INTRODUCTION

An important problem in the creation of supersonic and hypersonic aircrafts and missiles is to obtain reliable data on their aerodynamic heating and friction resistance on the streamlined surface on the basis of experiments in aerodynamic installations, the solution of Prandtl's nonlinear differential equations of the viscous boundary layer and Navier–Stokes nonlinear differential equations, flight tests. The equations of the viscous boundary layer, obtained by Prandtl under a number of assumptions, and the results of their solution require experimental verification, especially for turbulent and transient regimes of the flow of flight object surface using various turbulence models. For the Navier–Stokes equations, there is no proof of uniqueness of their solution, they require the application of sophisticated numerical solution methods using the method of determination in time, and a small parameter with the highest derivative complicates the solution to these equations, which fundamentally differ from the Prandtl's differential equations.

Wind tunnels are widely used in supersonic and hypersonic aerodynamics with the application of contact and optical research methods to simulate complex processes in the flow of supersonic and hypersonic objects. But modern high-speed aerodynamic installations have some disadvantages due to the fact that the most important similarity criteria such as the Mach and Reynolds numbers, as well as non-isothermicity in the boundary flow on the streamlined surface, the operation of both aircraft and missile engines, laminar-turbulent transition and relaminarization near the streamlined surface, atmospheric turbulence, vibrations, as well as the deformation of flight objects are not simultaneously simulated in them.

A special role in the creation of supersonic and

hypersonic objects is played by aerophysical and aerodynamic experiments, which enable to obtain reliable full-scale data on the level of wall temperature, heat fluxes to the walls, the distribution of static pressure along the length of the streamlined surface, the magnitude of the Reynolds number at the beginning of the laminar-turbulent transition in the wall jet and relaminarization in it, as well as on other important characteristics [1].

2. PROBLEM STATEMENT IN GENERAL TERMS

The flight data on the temperature of the streamlined surface of supersonic and hypersonic objects are essential to the collection of reliable information on various aerophysical processes in the wall boundary layers in flight [1]. One of the pressing issues is the problem of laminar-turbulent transition in wall viscous flows on flight objects, which is not reliably simulated in supersonic and hypersonic wind tunnels, and the problem of interaction between the laminar-turbulent transition and the separated flow on the surface of these objects is primarily due to the acoustic field in testing sections of wind tunnels, the failure to simulate the operation of rocket engines, the Mach and Reynolds numbers simultaneously, temperature factor, streamlined surface vibration and deformation.

The creation of supersonic and hypersonic flight objects gives rise to a range of problems associated with the need to obtain reliable quantitative data on heat exchange and surface-friction drag under aerodynamic heating, the influence of operating engines of different types with the effects of the flow compressibility, non-isothermicity, laminar-turbulent transition, and relaminarization (reverse transition) of the turbulent wall flow, elastically deformed condition of the streamlined surface and structural vibration in the wall boundary layer.

3. RECENT RESEARCH AND PUBLICATION ANALYSIS

One of the challenging aerodynamic and aerophysical issues is the laminar-turbulent transition in the viscous boundary layer on the streamlined surfaces of supersonic and hypersonic objects. The laminar-turbulent transition is one of the most significant challenges of high-speed aerodynamics and aerophysics, thermomechanics, thermophysics, continuum dynamics. The study of this problem is of fundamental scientific importance and relevance for solving practical problems of aviation, rocket and space technology, energy performance.

From a scientific and practical perspective, the problem of interaction and mutual influence of the laminar-turbulent transition and flow separation in the viscous wall boundary flow on the forebodies of supersonic and hypersonic missiles is relevant. This aerophysical process is generated by the flow separation from the streamlined surface of flying objects in the viscous wall boundary layer under laminar conditions, and the laminar-turbulent transition occurs in the separated flow above the surface of the forebody of supersonic and hypersonic objects. The separated laminar-turbulent flow is formed subject to the presence of positive longitudinal pressure gradient $\text{grad}P_x > 0$ in the wall flow, and after joining the streamlined surface, a large peak of heat flux occurs on it, significantly exceeding the average heat fluxes. The greatest local values of heat fluxes are obtained in the area of attachment of separated supersonic and hypersonic turbulent flows, which exceed the average heat fluxes by 10 or more times in comparison with the heat fluxes, for example, at the critical point during the flow past blunt bodies, to the streamlined surface. The work [2] is devoted to the problems associated with the laminar-turbulent transition in the high-speed aerodynamics. When creating supersonic and hypersonic flight objects, reliable data on the beginning of the laminar-turbulent transition and its length on the streamlined surface are required for reliable calculations of surface-friction drag and heat fluxes.

Until recently, on the one hand, the theory of laminar-turbulent transition in supersonic and hypersonic wall boundary layers on the surface of flight objects has not been completed that causes a number of difficulties in their design. On the other hand, it is impossible to obtain reliable data on the beginning of the laminar-turbulent transition and its length in modern supersonic and hypersonic wind tunnels due to the presence of the acoustic field generated by the turbulent boundary layer on their walls in the testing sections of wind tunnels. This leads to a significant decrease in the longitudinal coordinate of the laminar-turbulent transition and the length of the transitional phase to the appearance of the turbulent flow regime compared to the flight data. The data obtained under flight conditions differ in the turbulence spectra and scales from the wind-tunnel data, and there is impossibility to simulate the Mach and Reynolds numbers

simultaneously, and temperature factor, as well as the operation of rocket engines in wind tunnels [1, 2].

The flight data on the laminar-turbulent transition important from a scientific and practical perspective were obtained on the supersonic aerophysical missile complex [2] at the Mach numbers of the flow $M_\infty \leq 2.0$, Reynolds along the forebody length $Re_{L,\infty} \leq 2 \cdot 10^7$ under the operation of a solid-fuel jet engine (SFJE). In [3, 4] – on the forebodies of hypersonic space missiles at the maximum Mach numbers of the flow $M_\infty \leq 6.92 \div 10.7$ and the maximum Reynolds numbers of the flow through momentum thickness $Re_\theta \leq 38 \div 981$ at different flight altitude in the conditions of operating engines subject to the thermal protection of missiles [3]. The spectrum of vibration during the operation of sustainer engines was in the range of up to 10 kHz. The laminar boundary layer on the forebody of one of hypersonic missiles in [3] was observed up to the altitude of 3 ÷ 4 km, and at the altitude of 4 ÷ 6 km there was the transitional flow regime, and further along the trajectory there was a turbulent regime. The maximum values of the convective heat transfer coefficient on missile forebodies in [3] were at the Mach number $M_\infty \approx 2.0$. The maximum temperature of the thermal protection coating of hypersonic missiles in [3] reaches 900 K.

In [5] the images of flow field visualization and data on the laminar-turbulent transition in the wall flow at different Reynolds unit numbers and Mach numbers $M_\infty \leq 0.95 \div 1.7$ were obtained on the supersonic aircraft NASA F-15B on a plate mounted vertically under its fuselage, using the infrared thermograph. The boundary of transition to the turbulent wall-flow regime in [5] is extremely irregular across the plate width that can be caused by various disturbances due to vibrations at the place of installation of the plate and at its end associated with the operation of F-15B aircraft engine, with the plate streamlining, subject to a primary shock wave. Neither numeric data on the beginning of the laminar-turbulent transition and the length of the transitional viscous wall layer, nor the comparison with the results of other authors are presented in [3]. The data on the laminar-turbulent transition in flight conditions are given in [6-10]. In general, reliable data on the laminar-turbulent transition can be obtained only on supersonic and hypersonic flight complexes that is fundamentally important in the design of new complexes of a similar type [1].

4. PROBLEM STATEMENT AND RESEARCH GOAL IN GENERAL TERMS

In this article, the authors set the objective of scientific and practical importance to develop an effective airborne measuring electronic system and telemetry for a supersonic aerophysical missile complex based on the meteorological rocket, the forebody of which is equipped with semiconductor diodes CD-521 to study aerodynamic heating, the distribution of the wall temperature along the forebody length in flight along the trajectory with the transonic and supersonic speeds under the operation of a solid-fuel jet engine with acceleration of up to 12g in the conditions that are

simulated neither in supersonic wind tunnels, especially under the laminar-turbulent transition and relaminarization in the wall flow, nor by theoretical methods.

Aerodynamic heating in flight of a supersonic missile is accompanied in time by the formation of the forebody wall temperature. The use of flight data on the wall temperature, the results on the theory of laminar wall layer stability, the calculation of the flow Reynolds number in flight, the model of turbulent spots (Emmons spots) enable to obtain reliable numeric data on the beginning of the laminar-turbulent transition in the wall jet and its length. This requires the high quality and speed of electronic system, telemetry, high sensitivity of temperature sensors.

The goal of the study is to use a nonlinear differential equation for the unsteady wall temperature, spline functions for the approximation of the wall temperature in time and the possibility of further calculation of heat fluxes in laminar and transition surface flow regimes, calculations of local peaks of heat flux in the interaction of the laminar-turbulent transition and flow separation on the basis of reliable data on the wall temperature in the case of separated and unseparated flow of the forebody of an aerophysical missile complex in flight in time along the trajectory at the numbers of Mach $M_\infty \leq 2.0$, Reynolds $Re_{L,\infty} \leq 2 \cdot 10^7$ (L is the forebody length) with acceleration of $a \leq 12g$ under the operation of a solid-fuel jet engine. The flight data on laminar-turbulent transition, its length, wall temperature, local peaks of heat flux under the separation of the wall flow of forebodies of supersonic objects for such a complex are important for the design of reliable new objects, as well as for the formation of flight data bank.

5. PRESENTATION OF THE RESEARCH BASIC MATERIAL

The scientific significance of the problem of laminar-turbulent transition in viscous boundary layers on the streamlined surface of supersonic and hypersonic objects is contingent on complex linear and nonlinear processes associated with the influence of intensity, spectrum and scale of external disturbances, compressibility of flow, pressure gradient, surface temperature on the development of oscillations in laminar wall boundary layers depending on the type of external disturbances, with the presence of nonlinear oscillations, the loss of the laminar layer stability and the formation of three-dimensional vortex structures, Emmons turbulent spots, the merger of which is followed by the turbulent form of the wall flow at the coefficient of intermittency $\gamma = 1.0$.

The data on the Reynolds and Mach numbers in flight along the trajectory, the forebody wall temperature and the known numerical data from the theory of wall laminar boundary layer stability characterizing the dependence of the Reynolds number at the beginning of the laminar-turbulent transition on the Mach number of the incoming flow are required in order to obtain reliable flight data on the beginning of the laminar-turbulent transition and its length on the supersonic aerophysical missile complex. The

development of a high-precision method for measuring the temperature of the forebody wall of a missile complex is important in this regard.

The high-precision method of measuring the temperature of the supersonic complex wall in flight along the trajectory is based on the development of an electronic airborne system, telemetry, ground reception of flight data on the wall temperature. Semiconductor diodes C-521 are used as the wall temperature sensors along the forebody length. Diode CD-521 is a semiconductor device with the unilateral conductivity of electric current, which occurs as a result (p-n) of transition in the semiconductor. The range of temperature measurement based on diode CD-521 was $288 \div 393$ K, which was enough to use it on a supersonic object at the Mach numbers of the flow $M_\infty \leq 2.0$. The sensitivity of diode CD-521 was 2.5 mV/deg, and, for example, only 0.04 mV/deg in the chromel-aluminum thermocouple.

The calibration of diode CD-521 under laboratory conditions using the current-voltage characteristic showed that the dependence of output voltage on the temperature was linear in the temperature range of 288÷393 K. Fig. 1 shows the configuration of aerophysical missile complex, and Fig. 2 presents the diagram of its gasdynamic flow in flight at the Mach numbers $M_\infty \leq 2.0$, Reynolds numbers $Re_{L,\infty} \leq 2 \cdot 10^7$ with acceleration of $a \leq 12g$, flight altitude of $h \leq 8$ km under the operation of a solid-fuel jet engine.

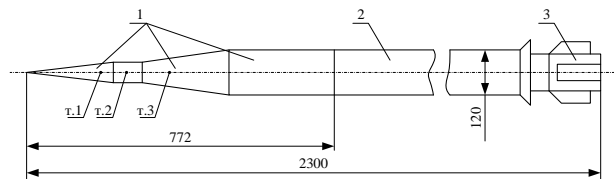

Fig. 1 – Configuration of reusable aerophysical missile complex based on the meteorological rocket: 1 – forebody; 2 – solid-fuel jet engine (SFJE); 3 – parachute compartment; point 1 – $X = 0.25$ m; $\delta_w = 4$ mm; material D16T; point 2 – $X = 0.28$ m; $\delta_w = 1.8$ mm; material D16T; point 3 – $X = 0.4$ m; $\delta_w = 1$ mm; material 1X18H9T.

This complex with the forebody equipped with the airborne electronic transmission system, temperature sensors CD-521, telemetry is developed on the basis of the use of a solid-fuel jet engine and parachute compartment of the meteorological rocket. The forebody is reusable and can be saved by a parachute. The temperature measurement at point 1 is carried out on the missile wall made of material D16T with the thickness of $\delta_w = 4$ mm at $X = 0.25$ m, at point 2 – made of material D16T with the thickness of $\delta_w = 1.8$ mm at $X = 0.28$ m, at point 3 – made of material 1X18H9T with the thickness of $\delta_w = 1$ mm at $X = 0.4$ m.

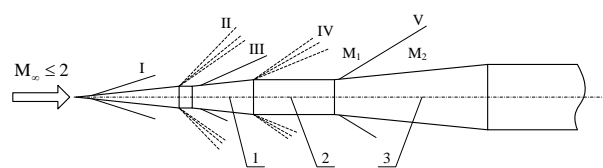

Fig.2 – Gasdynamic scheme of the flow of aerophysical complex forebody: I, III, V – shock waves; II, IV – expansion waves; 1, 2, 3 – points of placement of diodes CD-521:1 – X = 0.25 m; 2 – X = 0.28 m; 3 – X = 0.4 m.

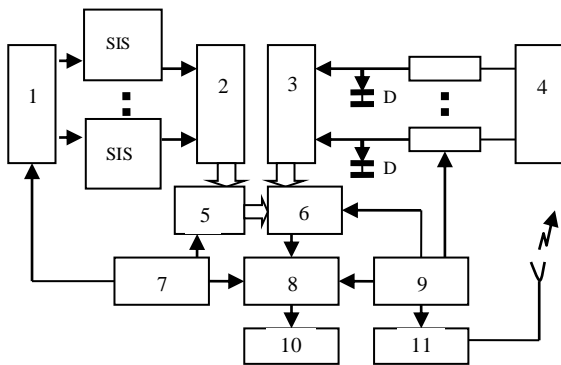

Fig. 3 – Airborne electronic measurement and transmission systems.

High requirements are imposed on the airborne electronic measurement and transmission system of supersonic aerophysical complex. Fig. 3 shows a diagram of such a system. The airborne electronic and telemetry systems have high speed and accuracy that enables to measure not only the temperature of the forebody wall of the missile system, but also the static pressure on the streamlined surface with the help of two sensors SIS. Small inductive sensors SIS are designed to measure the instantaneous and static values of inert gas pressure. The sensor SIS has two coils, membranes as sensing elements in the coils. Excessive pressure has an effect on the membranes, which are deformed. This deformation leads to change in the induced drag of coils for the value proportional to the displacement of membranes, and to the bridge unbalance. The voltage of bridge unbalance is proportional to the measured pressure. The sensors SIS, which are vibration-resistant and vibration-proof, in the frequency band from 10 to 600 Hz with acceleration of up to 20g, operate at linear acceleration of up to 100g. The efficiency of using sensors SIS is demonstrated by the authors in flight experiment on one of aerophysical missile complexes in the measurement of static pressure on its forebodies in the range of the Mach number of the flow $1.6 \leq M_\infty \leq 4.2$ [1].

The main objective of this article is to measure the temperature of the wall of the supersonic complex forebody (see Fig. 1) based on the airborne electronic and transmission system (see Fig. 3), semiconductor diodes CD-521. The airborne electronic and transmission systems (see Fig. 3) operate as follows. Diodes CD-521 at three points on the forebody (see Fig. 1, 2) were measured after 5ms, and the temperature measurement error was not more than 1% that is a significant achievement for flight experiments.

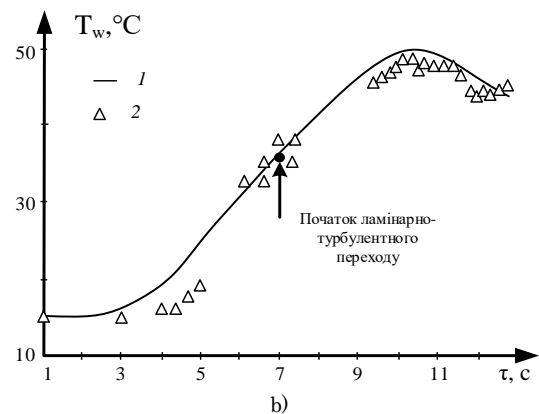
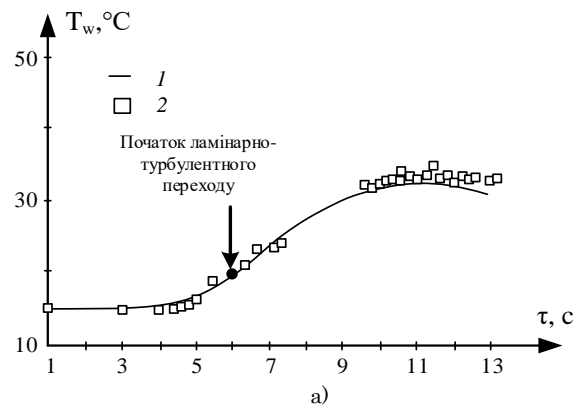

Fig. 4 – Change in temperature of the wall of the aerophysical complex forebody: a) point 1 – X = 0.25 m, $\delta_w = 4$ mm, material D16T; b) point 3 – X = 0.4 m; $\delta_w = 1$ mm, material 1X18H9T; 1 – calculation, 2 – flight experiment.

The sensors CD-521 were powered by constant current $0.5 \div 0.8$ mA from unit 4 during direct connection. The pressure sensors SIS were powered by a sinusoidal signal from pump 1 at a frequency of 8192 Hz. From units of the previous amplifiers 2 and 3, the amplified signal is transmitted from the sensors KD-521 and SIS to switches 5 and 6. With the help of units 7, 8 and 10, amplitude - frequency, autocalibration and correction of amplifier 10 are linearly transformed. The useful power of unit 9 was 15 W. When conducting the flight experiment on the supersonic aerophysical complex (see Fig. 1, 2), the information was recorded on the ground recording device followed by obtaining the values of the wall temperature along the length of the aerophysical complex forebody at three points (see Fig. 1, 2) in flight along the trajectory based on decoding the recorded flight data. Fig. 4a and Fig. 4b present the flight data on dependence of the wall temperature of the aerophysical missile complex forebody on the flight time τ along the trajectory.

The flight data on the wall temperature T_w of the forebody in Fig. 4a and Fig. 4b are highly precise, obtained for the first time with an accuracy of $0.5 \div 1.0\%$ under the operation of a solid-fuel jet engine at zero incidence. The flight experiments of the authors in [1] for measurement of zero angle of attack with the use of the Hall effect sensor on the other aerophysical missile complex at the Mach numbers of $M_\infty \leq 4.5$, Reynolds numbers of $Re_{L,\infty} \leq 2 \cdot 10^7$, with acceleration of

$a \leq 32g$ and a solid-fuel jet engine have shown that the operation of jet engines, of the two stages the angle of attack $\alpha=0$ has an error of 0.3 %. It should be emphasized that the flight data on the wall temperature shown in Fig. 4a and Fig. 4b contain information on flow regimes of the forebody of the aerophysical complex (see Fig. 1, 2) during its flight along the trajectory.

To solve the problem of flow regimes of the forebody of the research supersonic aerophysical complex, the laminar-turbulent transition in the viscous wall boundary layer, values of the Reynolds numbers Re_{tr} , the following analysis was made at the beginning of this transition: 1) comparison of the flight experiment data (see Fig. 4a, Fig. 4b) with the theoretical curves of hydro-dynamic stability of the supersonic viscous boundary layer in coordinates $T_w/T_e = f(M_e)$, where T_w is the wall temperature, M_e is the Mach number, T_e is temperature on the outer surface of the boundary layer, has shown that the flight data are beyond the laminar layer stability indicating the laminar-turbulent transition; 2) comparison of the flight experiment data on the wall temperature in time along the trajectory of the flight complex with the results of numerical calculation T_w using a non-stationary nonlinear differential equation only for the laminar flow regime or only for the turbulent flow regime of the complex forebody surface has shown that until the flight time $\tau \leq 6$ s for point 1 (see Fig. 4a) and until $\tau \leq 7$ s for point 3 (see Fig. 4b) the flow regime was laminar, and at $\tau \geq 6$ s and $\tau \geq 7$ s at these points the calculated values T_w for the laminar regime were less than the flight values, which meant that there was the beginning of the laminar-turbulent transition, with no turbulent flow regime. In the time range of the aerophysical complex flight along the trajectory from $\tau = (6\div 7)$ s to $\tau = 14$ s for two points (see Fig. 4a, Fig. 4b) the flow regime on the forebody was transient.

In the laminar-turbulent transition zone in the supersonic wall layer on the aerophysical complex forebody (see Fig. 1, 2) the non-stationary differential equation of wall temperature for the thin wall model is as follows:

$$\rho_w c_w \delta_w dT_w/d\tau = [a_l (1-\gamma) + a_t \gamma] (T_{r,e} - T_w), \quad (1)$$

where ρ_w, c_w, δ_w – density, heat capacity and wall thickness; a_l, a_t – heat transfer coefficients in laminar and turbulent flow; γ – coefficient of intermittency in the laminar-turbulent flow zone; $T_{r,e}$ – equilibrium air temperature on the outer surface of the wall boundary layer, T_w – wall temperature; at $\gamma = 0$ – laminar regime; at $\gamma = 1.0$ – turbulent regime.

The differential equation (1) is valid for the thin wall model applied to the aerophysical complex forebody (see Fig. 1, 2) since the criterion Bio is $Bi \leq 4 \cdot 10^{-2}$. The thin wall model means from a physical standpoint that there is no temperature difference in the wall thickness. The Strouhal number for the supersonic aerophysical complex is within the limits of $Sh = 10^3 \div 10^4$ that indicates the steadiness of gas-dynamic and thermal processes under the flow conditions. This has enabled to calculate heat transfer coefficients a_l and a_t on the basis of steady theoretical relations [2].

The intermittency coefficient γ in (1) is calculated with the use of the following formula, which is based on the Emmons' turbulent spot theory [2],

$$\gamma = 1,0 - \exp \left[- \frac{3,507}{A^2} \cdot Re_{tr}^{-1,34} \cdot \frac{u_e^2 \cdot \rho_e^2}{\mu_e^2} \cdot \left(\frac{\mu_{e,tr}}{u_{e,tr} \cdot \rho_{e,tr}} \right)^2 \times \right] \times (Re_{x,e}(\tau) - Re_x)^2 \quad (2)$$

In (2) $A = 60 + 4,68 M_e^{1,92}$; Re_{tr} is the Reynolds number at the beginning of the laminar-turbulent transition on the streamlined surface; M_e, u_e, ρ_e are the Mach number, speed and density of the flow on the outer surface of the viscous boundary layer; τ – time; $\mu_{e,tr}, \rho_{e,tr}, u_{e,tr}$ are dynamic viscosity coefficient, density and speed at the beginning of the laminar-turbulent transition, $Re_{x,e}(\tau)$ is the Reynolds number in flight time; indices e, tr mean parameters on the outer surface of the viscous boundary layer and at the beginning of the transition, respectively. From Fig. 4a and Fig. 4b it can be seen that the calculated data of the wall temperature based on time during the flight of the supersonic aerophysical complex (see Fig. 1) along the trajectory are reliably consistent with the authors' flight data on the forebody of this complex both for the laminar flow regime in a viscous wall layer at $\gamma = 0$ for the flight time $\tau \leq (6\div 7)$ s and for the transition regime at $\tau \geq (6\div 7)$ s using the results of the numerical solution to the nonlinear differential equation (1) for the two regimes and the additional ratio (2) for the intermittency coefficient γ , which varies from $\gamma = 0$ to $\gamma = 1.0$ in the laminar-turbulent transition zone.

Thus, the high-precision measurement of the wall temperature of the supersonic aerophysical missile complex using semiconductor diodes CD-521, the airborne electronic system and telemetry has enabled to establish on the basis of physical analysis and numerical calculation that the laminar and transition (laminar-turbulent) regimes of the surface flow are formed on the complex forebody, to determine the Reynolds number Re_{tr} at the beginning of the laminar-turbulent transition, to obtain the physically reasonable dependence of heat flux $q_w(\tau)$ on time to the streamlined surface. The data on $q_w(\tau)$ are shown in Fig. 5. The nonmonotonic character of the change in $q_w(\tau)$ in time during the object flight along the trajectory with its two maxima is seen, provided that the second maximum $q_w(\tau)$ is associated with the laminar-turbulent transition regime at $\tau \geq (6\div 7)$ s.

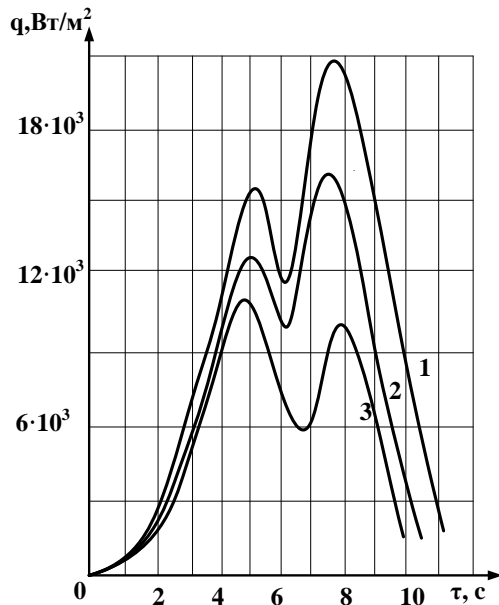

Fig. 5 – Change in convective heat flux along the trajectory in 3 points in the flow of the forebody of the aerophysical missile complex in flight at the Mach number $M_\infty \leq 2.0$, the Reynolds number $Re_{L,\infty} \leq 2 \cdot 10^7$, with acceleration of $a \leq 32g$.

All the data obtained in [2], as well as the data on the effect of a rocket engine on numbers Re_{tr} at the beginning of the laminar-turbulent transition in comparison with the NASA data given in [1] during free flight of pointed cones without engines, are important from the scientific and practical perspective.

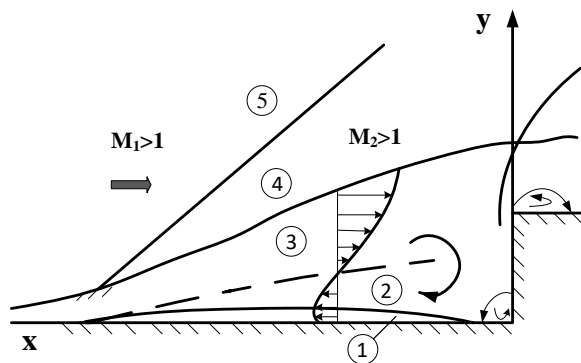

Fig. 6 – Physical picture of the flow under the supersonic flow separation before the step: 1 – wall boundary layer; 2 – inner mixing layer; 3 – outer mixing layer; 4 – external supersonic flow; 5 – oblique wave.

An important problem, which is theoretically and experimentally understudied, is the problem of interaction between the laminar-turbulent transition and flow separation in the supersonic flow of flight object surfaces. The separation of wall supersonic flows is formed on streamlined surfaces with a positive longitudinal pressure gradient $gradP_x > 0$ under the flow of a forward-facing step or compression corner on the surface, when the wall jet is affected by a compression wave [5].

The forward-facing step in the form of a ring with the height of $h = 5 \cdot 10^{-3}$ m and width of $b = 7 \cdot 10^{-3}$ m was

determined in order to study the interaction of laminar-turbulent transition and flow separation on a cylindrical part of the supersonic aerophysical missile complex (see Fig. 1, 2). The flow separation is one of the most complex phenomena in modern supersonic and hypersonic aerodynamics, which are understudied in flight conditions. The principal physical diagram of formation of the gas-dynamic pattern of the separated flow at the supersonic flow of the forward-facing step is shown in Fig. 6 in coordinates x, y in terms of a positive longitudinal pressure gradient $gradP_x > 0$. It is found above that without the wall flow separation the laminar wall layer has been formed on the aerophysical complex forebody (see Fig. 1, 2) before the time of flight along the trajectory of $\tau \leq (6-7)$ s, followed by the commencement of the laminar-turbulent transition flow regime at $\tau \geq (6-7)$ s (see Fig. 4). If the supersonic complex forebody has a forward-facing step, there is a longitudinal positive pressure gradient $gradP_x > 0$, resulting in the formation of complex gas-dynamic flow pattern (see Fig. 6) with the wall flow separation. Under these conditions, the wall boundary layer separation occurs in the laminar regime, and in the separation flow there is the laminar-turbulent transition. The separated laminar-turbulent flow joins the streamlined wall near the right angle between the surface of the complex forebody and the step with the formation of local peaks of the wall temperature and heat flux (see Fig. 7, Fig. 8). Local peaks of heat flux in the narrow zone of attachment of the separated wall layer to the streamlined surface can be, for example, for supersonic and hypersonic turbulent flow 10 or more times in comparison with heat fluxes to the point of wall layer separation. This fact should be considered when designing flight objects for various purposes. The relative length of the separation zone in the flight experiment under the interaction of the laminar-turbulent transition and separation in the wall layer $L/h \approx 15$, where h is the step height, L is the transition zone length, which is much larger than for the separation of supersonic turbulent wall layer that is physically understandable.

In the flight experiment, the peak temperature of the forebody wall was recorded at the point of the separated flow attachment to the forebody wall. Fig. 7 shows the flight data on the wall temperature distribution of T_w in time along the length of the complex forebody with the peak temperature at the point of attachment of the separated flow to the wall in the laminar-turbulent regime. The laminar-turbulent transition in the separated laminar wall layer is caused by the loss of flow stability, complex processes of non-isothermicity, heat and mass transfer, flow compressibility, the Reynolds and Mach numbers, longitudinal positive pressure gradient $gradP_x > 0$.

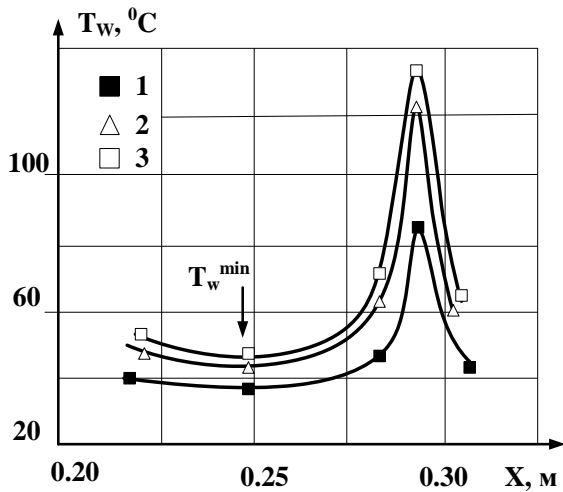

Fig. 7 – Distribution of the wall temperature in flight along the length of the aerophysical complex forebody at the interaction of the laminar-turbulent transition and wall flow separation at $M_\infty \leq 2.0$: 1 – $\tau = 6.24$ s; 2 – $\tau = 7.8$ s; 3 – $\tau = 9.36$ s.

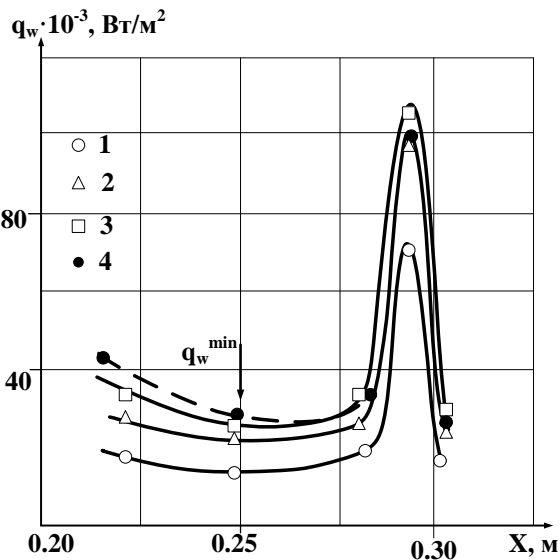

Fig. 8 – Distribution of heat flux to the wall in flight along the length of the aerophysical complex forebody under the interaction of laminar-turbulent transition and wall flow separation at $M_\infty \leq 2.0$: 1 – $\tau = 3.9$ s; 2 – $\tau = 4.7$ s; 3 – $\tau = 5.5$ s; 4 – $\tau = 6.25$ s.

The results on heat fluxes to the wall along the length of the aerophysical complex forebody with their maxima at the point of attachment of the separated flow to the wall for different moments of time on the

flight path of the complex have been obtained with the use of the nonlinear differential equation $q_w = \rho_w c_w \delta_w dT_w/d\tau$ for the thin wall model and the approximation of experimental data on the wall temperature T_w by a cubic spline (see Fig. 8). The maximum value of heat flux q_w at the point of attachment of the separated wall flow is 4 times bigger than q_w to the point of flow separation.

CONCLUSIONS

1. A high-precision method for measuring the wall temperature along the length of the forebody of the supersonic aerophysical missile complex under motion along a trajectory with the Mach number $M_\infty \leq 2.0$, the Reynolds number $Re_{L,\infty} \leq 2 \cdot 10^7$ with acceleration of $a \leq 12g$ to the altitude of $h \leq 8$ km under the operation of a solid-fuel jet engine (SFJE) based on semiconductor diodes CD-521, electronic onboard system and telemetry, has been firstly implemented.

2. The airborne electronic system of the supersonic aerophysical complex has provided the survey (after 5 ms) of semiconductor diodes CD-521 with a sensitivity of 2.5 mV/deg, and the whole airborne electronic system and telemetry have ensured the wall temperature measurement within the accuracy of $0.5 \div 1.0\%$.

3. The high-accuracy data on the wall temperature T_w along the length of the aerophysical missile complex forebody at the attached flow of its surface have enabled, using the known theoretical results and the results of the authors' calculations, to establish that on the forebody at various points along its length the laminar and laminar-turbulent regime occurs in time in the wall layer, to obtain reliable data on the Reynolds number at the beginning of the laminar-turbulent transition in the boundary layer with the presence of the transition flow regime, for the first time to put the theory of Emons' turbulent spots to the test in flight conditions under the operation of a solid-fuel jet engine (SFJE).

4. The data on the temperature of the aerophysical complex forebody wall under the interaction of the laminar-turbulent transition and separated wall flow have enabled to obtain reliable results on local peaks of temperature and heat flux at the points of attachment to the separated flow wall in the transition regime, and in this case the local peaks of heat flux are four times bigger than the heat flux to the point of flow separation.

REFERENCES

1. A.M. Pavliuchenko, O.M. Shyiko, *Aerospace Engineering and Technology* **130** No. 3, 68 (2016). (A.M. Pavljuchenko, A.N. Shijko, *Aviacionno-kosmicheskaja tehnika i tehnologija* **130** No 3, 68 (2016) [In Ukrainian].
2. A.I. Leontiev, A.M. Pavliuchenko, *HIGH TEMP+* **46** No. 4, 596 (2008).
3. I.I. Ibraeva, *Scientific Notes of Central Aero-Hydrodynamic Institute*, **36**, No. 1-2, 70 (2005).
4. I.I. Yurchenko, I. N. Karakotin, *Science and Education*. No. 9, 88 (2014).
5. M.A. Frederick, D.W. Banks, G.A. Garson, J.R. Matischeck, NASA/TM – 2015 – 218940, 1 (2015).
6. D.W. Banks, C.P. van Dam, H.I. Shui, G.M. Miller, NASA/TM – 2000 – 209027, 1 (2000).
7. S. Schneider, *Journal of Spacecraft and Rockets*, **43**, No 6, 1153 (2006).

8. D.C. Reda, M.C. Wilder, D.W. Bogdanoff, D.K. Prabhu, *Journal of Spacecraft and Rockets*, **45**, No 2, 210 (2008).
9. D.W. Banks, M.A. Frederick, R.R. Tracy, J.R. Matisheck, N.D. Vanacek, *15th International Symposium on Flow Visualization (ISFV15)*, 062 (Minsk: Belarus: 2012).
10. G.A. Garson, J.R. Matisheck, D.W. Banks, M.A. Frederick, *32nd AIAA Applied Aerodynamics Conference (AIAA AVIATION Forum)*, AIAA 2014-2841, 1, (Atlanta: USA: 2014).