

CONSTRUCTION OF AN ALGORITHM FOR THE SELECTION OF RIGID STOPS IN STEEL-CONCRETE BEAMS UNDER THE ACTION OF A DISTRIBUTED LOAD

A. Petrov

PhD, Associate Professor
Department of Building and Civil Engineering*

And. Paliy

Doctor of Agricultural Sciences, Associate Professor
Department of Technical Systems and Animal Husbandry Technologies*
E-mail: paliy.andriy@ukr.net

M. Pavliuchenkov

PhD, Senior Lecturer
Department of Structural Mechanics and Hydraulics
Ukrainian State University of Railway Transport
Feierbakha sq., 7, Kharkiv, Ukraine, 61050

H. Tsyhanenko

Senior Lecturer
Department of Building Structures**
Sumy National Agrarian University
Herasyma Kondratieva str., 160, Sumy, Ukraine, 40021

N. Khobot

Assistant
Department of Architecture and Engineering Studies**

I. Vysochin

Doctor of Architecture, Professor
Department of Architecture and Engineering Studies**

O. Yurchenko

PhD, Lecturer
Department of Construction Technology**

O. Ovcharenko

PhD, Associate Professor
Department of General Trainin***

D. Sopov

Acting Director of the Educational Scientific Institute of Construction***

A. Paliy

Doctor of Veterinary Sciences, Professor
Laboratory of Veterinary Sanitation and Parasitology
National Scientific Center «Institute of Experimental and Clinical Veterinary Medicine»
Pushkinska str., 83, Kharkiv, Ukraine, 61023

*Kharkiv Petro Vasylenko National Technical University of Agriculture
Alchevskykh str., 44, Kharkiv, Ukraine, 61002

**Sumy National Agrarian University
Herasyma Kondratieva str., 160, Sumy, Ukraine, 40021

***Luhansk National Agrarian University
Slobozhanska str., 68, Starobilsk, Ukraine, 92703

Розроблений алгоритм підбору жорстких упорів в сталобетонних балках при дії розподіленого навантаження. Бетон зі сталевією смугою з'єднується жорстко з метою досягнення сумісної роботи бетону та сталевієї смуги. Таке з'єднання в балці забезпечують жорсткі упори, які перешкоджають зусиллям зсуву в зоні контакту бетону і сталі. Зусилля визначаються через кути повороту між двома сусідніми перерізами балки. Для визначення кутів повороту використовується графо-аналітичний метод визначення переміщень. При визначенні деформацій сталобетонної балки розрахунок ведеться за приведеними жорсткостями поперечних перерізів.

Ціль дослідження полягає в оптимізації конструкції сталобетонної балки за рахунок підбору раціональної кількості і розташування жорстких упорів. Така оптимізація дозволяє більш раціонально використовувати матеріал конструкції – бетон і сталь. Це призведе до зниження працездатності і кількості потрібних матеріалів при виробництві, монтажу та експлуатації розглянутих конструкцій.

Запропонований раніше алгоритм підбору жорстких упорів в сталобетонних балках при дії зосередженої сили розвинуто на випадок дії рівномірно розподіленого навантаження. При підборі кількості жорстких упорів передбачається, що величина діючого на балку розподіленого навантаження, механічні характеристики матеріалів (сталі та бетону), а також проліт балки і розміри її поперечного перерізу відомі. На відміну від балок із зосередженою силою посередині, де зусилля змінюються за лінійним законом, в балках з рівномірно розподіленим навантаженням зусилля в сталевій смузі змінюються по квадратній параболі. Тому, хоча і було отримано однаковий крок упорів, неможливо знайти положення, при якому зусилля в усіх упорах приймають однакові значення

Ключові слова: сталобетонна балка, жорсткий упор, крок упорів, зусилля в упорі, приведена жорсткість, графо-аналітичний метод

Received date 05.02.2020

Accepted date 27.05.2020

Published date 19.06.2020

Copyright © 2020, A. Petrov, And. Paliy, M. Pavliuchenkov, H. Tsyhanenko,

N. Khobot, I. Vysochin, O. Yurchenko, O. Ovcharenko, D. Sopov, A. Paliy

This is an open access article under the CC BY license (<http://creativecommons.org/licenses/by/4.0>)

1. Introduction

Construction is an intensively evolving industry around the world. The number of objects under construction is con-

stantly growing. As the number of buildings and facilities grows, the need for construction structures increases. This growth leads to the emergence of a variety of types and designs of new structures and new structural solutions. At

present, this diversity includes more and more steel-concrete structures.

Despite the emergence of new and modified materials, the most used material is concrete. Although numerous studies address concrete, many issues have remained unresolved. This material also provides great opportunities for its improvement. Papers [1–3] report studies aimed at increasing the strength of concrete and improving its mechanical characteristics at stretching.

In addition, there are both new and improved types of structures, which makes it possible to more efficiently use building materials. It is known that concrete operates well in terms of compression but is almost incapable of perceiving stretching stresses. The easiest solution to this problem is to reinforce the concrete. Currently, structures with external reinforcement, including steel-concrete ones, are increasingly used. In particular, steel-concrete beams have been widely applied. Such beams, although they have shown their effectiveness, still have a series of understudied problems. For example, the issue of joint operation of a steel sheet and concrete. To make them operate in concert, it is necessary to combine concrete and steel into a single structure. Perhaps the most common way is to use rigid stops and flexible anchors. It is of interest to optimize the structure of a steel-concrete beam by selecting the rational number and arrangement of rigid stops. Such an optimization would allow more rational use of concrete and steel, which, in turn, could lead to a reduction in labor costs and in the amount of materials required in the production, installation, and operation of the structures in question. That allows us to argue about the relevance of such research.

2. Literature review and problem statement

Many studies are aimed at improving the mechanical properties of concrete, including its operation at stretching. Currently, most research is aimed at improving the properties of concrete by adding various components to it. For example, rubber was added to the concrete composition in paper [1]. Work [2] reports a study of concrete with the addition of metal fibers. Study [3] considers the use of steel fiber with its orientation along the beam. It should be noted that the area of the cited research is to improve the properties of the material, not the structural features of beams.

The joint application of steel and concrete in beams leads to new challenges. These are the ways in which the stops are connected to the sheet, and the choice of their rational quantity. The regulations [4–6] provide certain recommendations for the use of stops and anchors. However, there are no strict restrictions, which makes it possible to vary both the number of stops and their arrangement. Ultimately, the rational location and number of rigid stops would optimize the structure of a steel-concrete beam.

Work [7] examines the structures operating in areas with increased seismic activity. The cited study showed that steel-concrete structures are well-reliable and could be used under operational conditions that differ from typical conditions by their increased complexity.

Most research involves numerical studies into steel-concrete structures. Papers [8, 9], for example, explore different techniques for introducing structural changes in order to optimize the structure operation in general. An important issue is a connection between steel and concrete. The cited papers

use the connection that is enabled by anchors. The issue of the optimization by the correct arrangement of anchors and the choice of their rational quantity is not considered.

Work [10] shows that the anchors themselves can increase the strength of a steel-concrete structure. The experimental studies in [11] examine the features of the operation of the pre-stressed steel-concrete elements. Paper [12] considers a change in the strength characteristics of steel-concrete structures depending on the amount of reinforcement. Study [13] addresses the adjustment of a neutral axis location depending on the change in the size of the cross-sections of a structure. Our analysis of papers [10–13] reveals that the solutions proposed in them improve the characteristics of steel-concrete structures and, thus, are of practical significance. However, they investigated a different area. The rational use of anchors was not considered although anchors are used in the structures.

Admittedly, a technique to connect steel and concrete through rigid stops or flexible anchors is not the only one. There are studies [14, 16] in which the elements of the structure are connected with the help of various adhesives, including acrylic. While it has its advantages, this technique cannot be considered universal. Thus, one can say that the use of glue to connect steel and concrete, although it has the right to exist, is not yet able to replace all other techniques.

At present, in most cases, rigid stops or flexible anchors are used for this purpose. This connection technique was considered in works [16, 17]. Thus, a new type of steel-concrete beams was proposed in [16]. The structure of such a beam is a reinforced concrete shelf with a reinforcement frame and a steel tee element. The study focuses on the use of different types of connections between concrete compounds and a steel tee element. An experimental study of five series of steel-concrete beams was reported in [17]. The series differed by the different ratios of sheet and rod reinforcement. The purpose of the cited study, among other things, was to establish the optimal ratio of the use of sheet steel St-3 in combination with the rod fixture of classes At-800 and A-1000.

The results of studying the stressed-strained state of steel-concrete beams were reported in [18]. The connection of a steel sheet and concrete involved flexible anchors. It was shown that flexible anchors have a certain malleability. In addition, the connection of the anchors to a steel sheet can be executed in a variety of ways. This variety of structure solutions creates some difficulties for devising a single calculation procedure. Different types of flexible anchors have varying degrees of malleability. Accounting for the malleability of a flexible anchor greatly affects the carrying capacity of the structure. And the calculation procedure often does not take into consideration the malleability of flexible anchors at all or accounts for it insufficiently accurately. Thus, the issues related to compiling a single procedure for the calculation of flexible anchors remain unresolved.

Paper [19] reports the field experimental studies of composite beams. The steel-concrete beams are reinforced with steel sheets. A new simplified system of anchors (a system of direct-shift bolt slabs) was proposed to strengthen the reinforced concrete beam. It is shown that the proposed system is effective for ensuring that the beam elements work together. The number of anchors was not considered. Work [20] reports an experimental study of steel-concrete beams. The steel sheet was attached to the concrete by bonding. Glued connections could become an alternative to con-

necting through rigid stops but the application of this technique is currently labor-intensive and not always possible.

Paper [21] studied concrete structures with the addition of liquid glass. This approach improves the physical and mechanical properties of concrete, in particular, its corrosion resistance. However, the cited study aimed to improve the properties of the material, rather than those of the structure.

Work [22] describes the results of the optimization of steel-concrete beams; in particular, a steel-concrete beam on two supports was considered. The technique for the external loading on a beam was accepted in the form of a concentrated force. The force is applied in the middle of the span. In practice, many beams operate under the action of an evenly distributed load applied along its entire length. Extending the procedure, proposed in [22], on the beams operating under the influence of distributed load, would optimize such structures by the rational arrangement of rigid stops.

All this suggests that it is appropriate to conduct a study on the effective arrangement of rigid stops.

3. The aim and objectives of the study

The aim of this study is to extend an algorithm for the selection of rigid stops in steel-concrete beams for the case of an evenly distributed load. This would make it possible to rationally use the materials of the structure – steel and concrete, which could reduce the amount of the material and the labor costs in the production, installation, and operation of steel-concrete beams.

To accomplish the aim, the following tasks have been set:

- to determine, through the rational arrangement of rigid stops, the same step of the stops lengthwise a beam, similarly to how it was obtained under the action of a concentrated force, which would ultimately optimize the structure of a steel-concrete beam;

- to verify the validity of the research by conducting a numerical experiment.

4. Materials and methods for constructing an algorithm for the selection of rigid stops in steel-concrete beams under the action of a distributed load

This research applies a procedure regulated by normative documents [4–6]. We also used existing methods for the calculation of steel-concrete beams.

It is believed that the steel and concrete in a structure work together, without detachment and slippage, which is regulated in [4, 5]. Concrete and steel work together through the use of rigid stops. The same regulations require that the stops should be absolutely rigid.

The arrangement of rigid stops prevents the horizontal shift of a steel sheet relative to the concrete in the beam. The efforts that arise in the stops can be determined by identifying the turning angles in the cross-sections between the adjacent stops. Next, the number and step of the stops is determined. A mechanism for determining the turning angles is a graph-analytical method for determining displacements.

The cross-section of a steel-concrete beam is heterogeneous. It consists of steel and concrete. The rigidity and geometric characteristics of such a cross-section are the reduced quantities.

5. Calculating the rational arrangement of rigid stops in a beam under the action of a distributed load

An algorithm for selecting rigid stops in steel-concrete beams depending on the action of a concentrated force in the middle of the beam was proposed in [22].

The effort acting on a stop is determined through the turning angles between the two adjacent stops. Therefore, we determine the lengthening of fibers through the turning angles of the cross-sections between the adjacent stops.

Because the differential equation of a curved beam axis is the same as that under the action of an evenly distributed load, the lengthening of the fibers would be determined in the same way as it was performed in [22]. The estimation diagram is shown in Fig. 1.

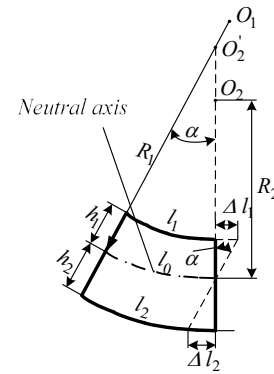

Fig. 1. An infinitely small element of a steel-concrete beam

Internal efforts in a beam under the action of an evenly distributed load q are calculated differently. The turning angle at point 1 would be equal to the fictitious shear force at this point. To this end, we determine the fictitious load derived in the form of a diagram of bending moments depending on the external load (Fig. 2, b).

The fictitious reactions are equal to

$$R_a^F = R_b^F = \frac{2}{3 \cdot 2} \frac{ql^2 \cdot l}{8} = \frac{ql^3}{24}.$$

Determine the load equivalent for a fictitious load for points 1 and 2

$$\omega_{x1} = \frac{2M_1 \cdot x_1}{3} = \frac{2qx_1 \cdot x_1(l-x_1)}{3 \cdot 2} = \frac{qx_1^2(l-x_1)}{3},$$

$$\omega_{x2} = \frac{2M_2 \cdot x_2}{3} = \frac{2qx_2 \cdot x_2(l-x_2)}{3 \cdot 2} = \frac{qx_2^2(l-x_2)}{3}. \quad (1)$$

The turning angle at point 1 at a distance $x = x_1$

$$\alpha_1 = \frac{1}{EJ}(-R_a^F + \omega_{x1}) = \frac{1}{EJ} \left(-\frac{ql^3}{24} + \frac{qx_1^2(l-x_1)}{3} \right) =$$

$$= \frac{q}{3EJ} \left(-\frac{l^3}{8} + lx_1^2 - x_1^3 \right). \quad (2)$$

The turning angle at point 2 at a distance $x = x_2$

$$\alpha_2 = \frac{1}{EJ}(-R_b^F + \omega_{x2}) = \frac{q}{3EJ} \left(-\frac{l^3}{8} + lx_2^2 - x_2^3 \right). \quad (3)$$

The reciprocal turning angle of cross-sections 1 and 2 is then equal to

$$\alpha_{1-2} = \alpha_1 - \alpha_2 = \frac{q}{3EJ} \left[-\frac{l^3}{8} + lx_1^2 - x_1^3 \right] - \left[\frac{q}{3EJ} \left(-\frac{l^3}{8} + lx_2^2 - x_2^3 \right) \right] = \frac{q}{3EJ} \left[-l(x_2^2 - x_1^2) + (x_2^3 - x_1^3) \right]. \quad (4)$$

This formula determines the reciprocal turning angle of the two cross-sections between points 1 and 2.

This formula holds if

$$0 < x_1, x_2 \leq \frac{l}{2}.$$

A sign in formula (4) is determined from the turn of the cross-section. If the cross-section turns clockwise, the turning angle's sign is negative, and vice versa.

The calculation of deformations for the reinforced concrete and steel-concrete beams is performed, according to the [4] and [18], based on the reduced rigidities of cross-sections and a normative load. The reduced rigidity is determined from the following formula

$$B = \phi_{b1} E_b I_{red}, \quad (5)$$

where I_{red} is the reduced axial inertia moment of the beam's cross-section; ϕ_{b1} is the factor that takes into consideration the effect of short-term concrete creep, taken for heavy concrete to be 0.85; E_b is the concrete deformation module.

A normative distributed load over sections without cracks is determined from the following formula

$$q^n = q^p \phi_{b2} \text{ or } q^n = \frac{8M^p \phi_{b2}}{l_p^2}, \quad (6)$$

where ϕ_{b2} is the factor that takes into consideration the influence of long-term creep of concrete; M^p is the bending moment due to the action of an estimated load on a beam; l_p is the estimated length of a beam.

It depends on the type of concrete, the environment, and the nature of load action (short or long), varies between 1 and 4.5, and is determined in line with [4, 18].

Therefore, formula (4) takes the following form

$$\alpha_{1-2} = \frac{q^n}{3B} \left[-l(x_2^2 - x_1^2) + (x_2^3 - x_1^3) \right]. \quad (7)$$

The reduced geometric characteristics of the cross-section are determined similarly to [22] from formulae (8) and (9). The scheme is shown in Fig. 3.

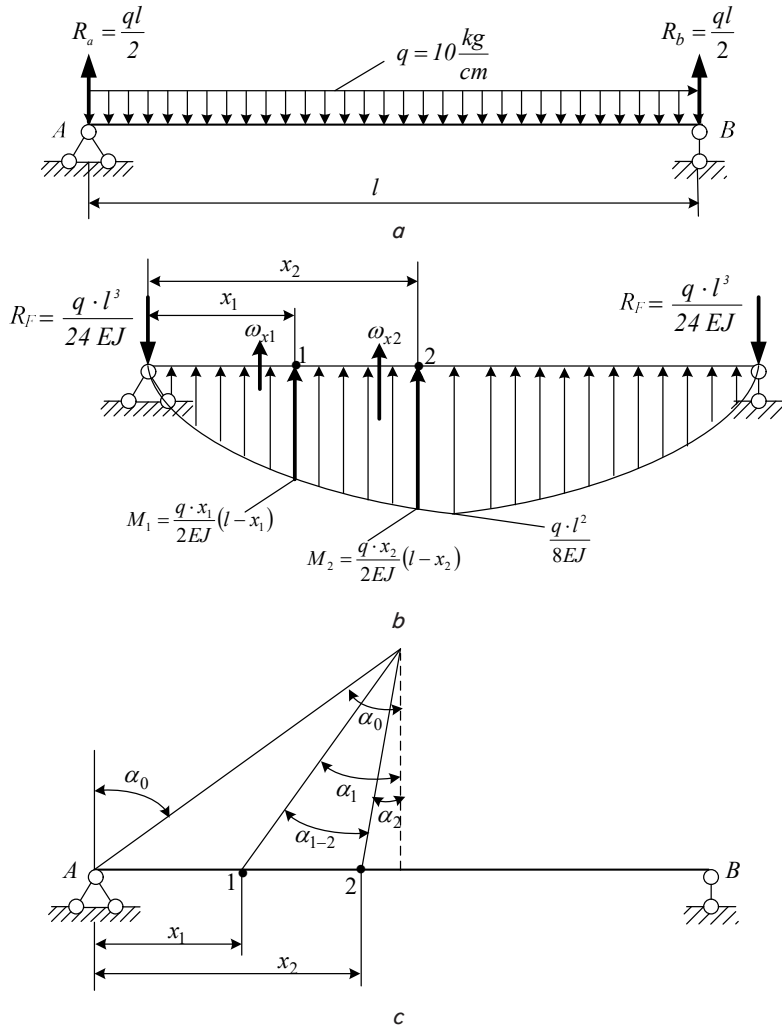

Fig. 2. Schematic for determining the reciprocal turning angles of two cross-sections in a beam's span: *a* – estimation diagram; *b* – bending moments diagram; *c* – a scheme to determine the reciprocal turning angles

$$z_c = \frac{S_{x1}}{A} = \frac{bh \left(\frac{h}{2} + \delta \right) + bn_1 \frac{\delta^2}{3}}{bh + b\delta n_1}, \quad (8)$$

$$I_{red} = \frac{bh^3}{12} + bh \left(z_c - \frac{h}{2} \right)^2 + \frac{b\delta^3}{12} n_1 + n_1 b \delta \left(z_c - \frac{\delta}{2} \right)^2. \quad (9)$$

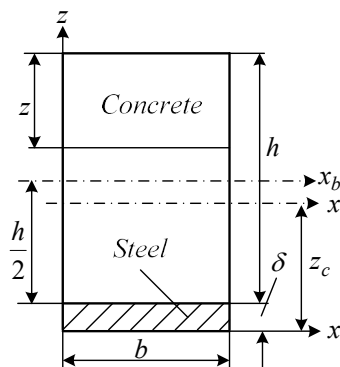

Fig. 3. Schematic for determining the geometric characteristics of a beam

Given the symmetry, we would consider half of the beam to determine the efforts. A step of the rigid stops n is not constant (Fig. 4). In contrast to beams loaded with a concentrated force in the middle, it is impossible, under the action of a distributed load, to achieve a constant step of the stops and a constant effort on them as the law of change in turning angles is nonlinear. In this case, the step is to be accepted constant; the efforts perceived by the stops – variable.

Taking into consideration the fact that the neutral axis passes through the center of gravity of the reduced cross-section, the lengthening of the middle of a steel sheet in the steel-concrete beam, the section of length $c = x_2 - x_1$, is determined using formula $\Delta l_2 = \alpha \cdot h_2$.

The distance from the neutral axis to the center of gravity of the steel sheet equals

$$b_1 = z_c - \frac{\delta}{2}.$$

The lengthening of the beam fiber between two cross-sections 1 and 2:

$$\Delta l_c = \alpha_{1-2} \cdot b_1 = \frac{q^n}{3B} \left[\frac{-l(x_2^2 - x_1^2) + (x_2^3 - x_1^3)}{+} \right] \left(z_c - \frac{\delta}{2} \right). \quad (10)$$

To determine the longitudinal force acting between the two adjacent stops, it is necessary to determine the relative lengthening of this section

$$\begin{aligned} \varepsilon &= \frac{\Delta l_c}{c} = \frac{(x_2 - x_1)}{(x_2 - x_1)} \frac{q^n}{3B} \left[\frac{-l(x_2 + x_1) + (x_2^2 + x_1x_2 + x_1^2)}{+} \right] \left(z_c - \frac{\delta}{2} \right) = \\ &= \frac{q^n}{3B} \left[-l(x_2 + x_1) + (x_2^2 + x_1x_2 + x_1^2) \right] \left(z_c - \frac{\delta}{2} \right). \end{aligned} \quad (11)$$

The longitudinal force over the section of length $c = x_k - x_i$ acts as a result of lengthening the steel sheet, which is determined from the following formula:

$$\begin{aligned} N_{i-k} &= \sigma_s \cdot A_s = \varepsilon_s \cdot E_s \cdot A_s = \\ &= \frac{q^n}{3 \cdot B} \left[\frac{-l(x_i + x_k) + (x_i^2 + x_i x_k + x_k^2)}{+} \right] \left(z_c - \frac{\delta}{2} \right) \cdot E_s \cdot A_s = \\ &= \frac{q^n}{3 \cdot B} \left(z_c - \frac{\delta}{2} \right) \cdot E_s \cdot A_s = \\ &= A_1 \left[-l(x_i + x_k) + (x_i^2 + x_i x_k + x_k^2) \right], \end{aligned} \quad (12)$$

where

$$A_1 = \frac{q^n}{3B} \left(z_c - \frac{\delta}{2} \right) E_s \cdot A_s. \quad (13)$$

In these formulae: A_s is the area of the cross-section of a steel sheet; σ_s is the stress in a steel sheet; E_s is the module of elasticity of steel; δ is the thickness of a steel sheet; x_1 is the distance from a stop to the first point; x_2 is the distance from a stop to the second point; z_c is the position of the center of gravity of the reduced cross-section; q^n is the intensity of the distributed normative external load acting on a beam.

The external load can be both calculated and normative load.

Knowing how to determine the longitudinal force at each section between the stops, one can determine the efforts in them.

The step of the stops is determined depending on the height of the beam, the height of the stop, and the height of the compressed zone of concrete $c = 2h_y$. Then

$$c = 2(h - z). \quad (14)$$

The length of the zero section is accepted, similarly to that under the action of a concentrated force [19], to be equal to:

$$x = \frac{c}{2}. \quad (15)$$

To determine the number of stops, we express the length of the beam through the lengths of the sections and the number of stops $\frac{l}{2} = nc + x$ or $l = 2nc + 2x$. Substitute the value (15)

$$l = 2nc + 2 \frac{c}{2} = 2nc + c.$$

Hence

$$n = \frac{l - c}{2c}. \quad (16)$$

If necessary, the length of the sections and the number of stops can be different, but conditions (14) to (16) must be met.

Since the longitudinal force over each section is a square parabola (12), it is necessary to try to determine the section with an extreme value. To this end, we highlight at one of the sections (Fig. 4, section 2) a small element of length a with a distance to the beginning of the element x_1 and to the end of the element x_2 . Using formula (12), we record the expression of the longitudinal force for a small element of length a . Then $x_1 = x$, and $x_2 = x + a$. In this case,

$$\begin{aligned} x_1 + x_2 &= 2x + a, \quad x_1^2 = x^2, \\ x_2^2 &= x^2 + 2ax + a^2, \quad x_1 x_2 = x^2 + ax. \end{aligned}$$

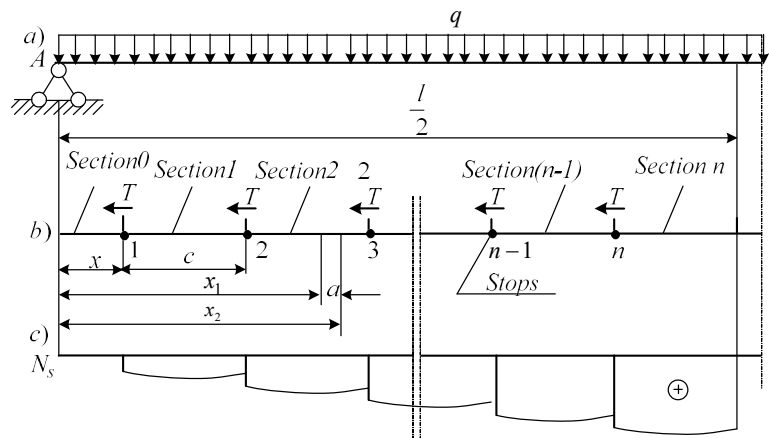

Fig. 4. Schematic for arranging rigid stops and the diagram of longitudinal forces in a steel strip: a – estimation diagram; b – a diagram of the arrangement of rigid stops; c – a diagram of longitudinal forces

Substitute the values into formula (12)

$$N_a = A_1 \left[-l(x_i + x_k) + (x_i^2 + x_i x_k + x_k^2) \right] = A_1 \left[-l(x + x + a) + \left(x^2 + x^2 + ax + ax + x^2 + 2ax + a^2 \right) \right],$$

$$N_a = -2lA_1 - A_1 la + 3A_1 x^2 + 3A_1 ax + a^2.$$

Take a derivative for magnitude x and equate to zero

$$N'_a = -2A_1 l + 6A_1 x + 3A_1 a, \quad -2A_1 l + 6A_1 x + 3A_1 a = 0.$$

Hence, we determine

$$x = \frac{2A_1 l - 3A_1 a}{6A_1} = \frac{2l - 3a}{6}. \tag{17}$$

As the magnitude a is small, then

$$x = \frac{2l - 0}{6} = 0.333l. \tag{18}$$

The formula (18) determines the distance from stop A to the point with a maximum value of the longitudinal force in a steel strip. This point does not always coincide with the middle of the beam. This is due to the law of changing the turning angles of cross-sections lengthwise the beam, which follows a cubic parabola, the longitudinal force – a square parabola.

We performed calculations for other lengths and loads. All of them confirm the derived condition. The extreme value of the longitudinal force in the strip for the half-length of the beam on two stops would be at a distance $x = 0.333l$. The maximum value of the longitudinal force in a steel strip is determined from formula (12).

The longitudinal force changes by a linear law [22] for a concentrated force. Therefore, there the load does not affect the law of changing the longitudinal force in a steel strip. However, the discrepancy between the maximum value of the longitudinal force in the steel strip and that in the middle of the beam does not affect the selection of stops in steel-concrete beams. In this case, the maximum value of the longitudinal force, obtained from formula (12), should be compared to the estimated effort for the middle of the span, derived for the action of an estimated load, obtained in [23] to test the stresses in the concrete and steel sheet.

$$N^p = \frac{M^p}{a_1} = \frac{q^p l_p^2}{8a_1}, \tag{19}$$

where

$$a_1 = h_0 - \frac{z}{2}.$$

The maximum value of the force acting on the stops can be determined based on the diagram of longitudinal forces in a steel strip. Practical experience shows that the maximum value of the force acting on the stops would be typically equal to the longitudinal force over the first section. Over other sections, the forces on stop T would be less.

With a set of formulae, one can select a step, the number of rigid stops, and determine efforts in them.

The result of our research is an algorithm for the selection of rigid stops if one knows the characteristics of the materials, the size of the beam cross-sections, the length of the beam, and the external load acting on the beam. The sequence of actions, according to the proposed algorithm, is given below.

The formula (6) determines the normative distributed load

$$q^n = \frac{8M^p \phi_{b2}}{l_p^2}, \quad q^n = q^p \phi_{b2}.$$

The formula (9) defines the reduced axial inertial moment of the cross-section of a beam

$$I_{red} = \frac{bh^3}{12} + bh \left(z_c - \frac{h}{2} \right)^2 + \frac{b\delta^3}{12} n_1 + n_1 b\delta \left(z_c - \frac{\delta}{2} \right)^2.$$

The formula (5) determines the reduced rigidity of the cross-section

$$B = \phi_{b1} E_b I_{red}.$$

The formula (13) determines the coefficient

$$A_1 = \frac{q_n}{4B} \left(z_c - \frac{\delta}{2} \right) E_s \cdot A_s.$$

The formula (14) determines a step of the rigid stops

$$c = 2(h - z).$$

The formula (17) determines the length of a zero section

$$x = \frac{c}{2}.$$

The formula (16) determines the number of rigid stops

$$n = \frac{l - c}{2c}.$$

The formula (18) determines the point with a maximum value of the cross-section turning angle.

This cross-section would be exposed to the action of maximal longitudinal force, acting on the strip due to the normative load, which is determined from formula (12).

A diagram of the longitudinal forces in a strip is built. The diagram determines the maximum value of the force acting on the stops. One can use formula (12) to record an expression to determine the longitudinal force T over the first section. This value is equal to the force acting on the stops.

The maximum value of the longitudinal force acting on the strip is compared with the value obtained from formula (19).

Knowing the efforts acting on the stops, their step, and quantity, one selects their size.

6. Results of numerical experiment

A numerical experiment was carried out to calculate the considered steel-concrete beam (Fig. 1–4). The beam span, similarly to [22], was accepted equal to 2 m. The magnitude

of the acting distributed load is 5 kN/m. As the load was changed in comparison with [22], other results have been obtained. The results are shown in Fig. 5.

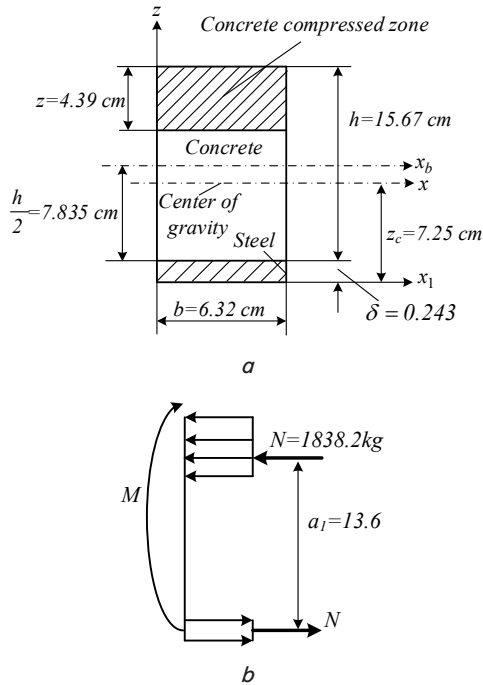

Fig. 5. Cross-section of a steel-concrete beam: a – cross-section of the beam; b – internal efforts

The calculation produced the following results: a step of the stops is 22 cm, a zero span is 11 cm. The maximum effort magnitude in a rigid stop is 9.92 kN. The maximum longitudinal effort in a steel sheet is 18.372 kN, which is equal to the limit value calculated from the same algorithm. The schematic of the beam and the diagram of longitudinal forces in a steel sheet are shown in Fig. 6.

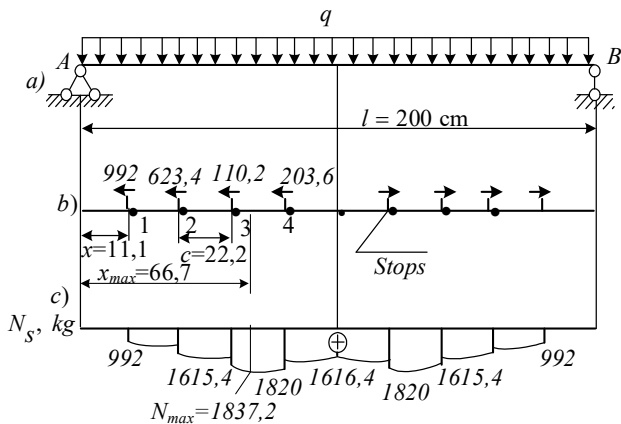

Fig. 6. The arrangement of stops and the diagram of longitudinal forces in a steel sheet: a – an estimation diagram; b – arrangement scheme of rigid stops; c – the diagram of longitudinal forces

The stresses in the steel-concrete beam sheet, obtained from the results of the numerical experiment, are shown in Fig. 7. The arrangement scheme of anchors is shown in Fig. 8.

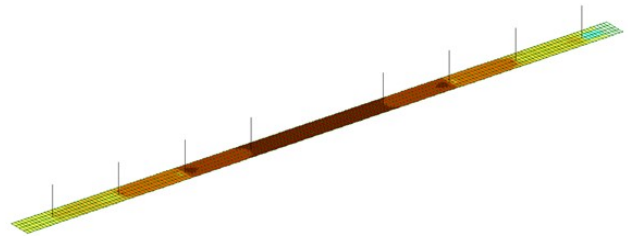

Fig. 7. A model of the steel-concrete beam

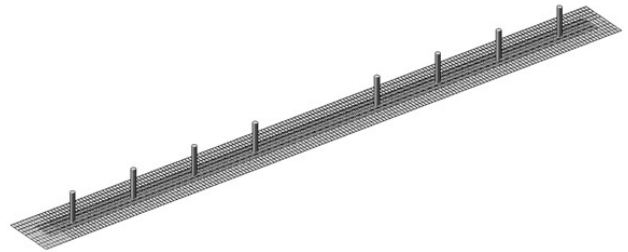

Fig. 8. The anchor arrangement scheme

The results of our numerical experiment coincide with the results of the calculation based on the proposed algorithm.

7. Discussion of results of constructing an algorithm for the selection of rigid stops in steel-concrete beams under the action of a distributed load

The result of our study is the constructed algorithm that makes it possible to calculate the number and a step of the rigid stops. In contrast to the beams loaded with a concentrated force in the middle, it is impossible, under the action of a distributed load, to reach a constant step of the stops and a constant effort on them. This relates to that the law of changing the turning angles is non-linear. In this case, the step is assumed to be constant and the efforts perceived by the stop – variable. The effort in a steel sheet and the effort in concrete are also the same and correspond to the limits. This would cause the simultaneous destruction of concrete and the steel sheet. Consequently, the material of the structure, concrete and steel, are utilized more rationally, which is the optimal structure in terms of material savings.

The proposed algorithm could be used for beams loaded throughout the entire length. A given algorithm was built by refining the earlier proposed algorithm implying the loading by the force applied in the middle of the span [22]. Similarly to the case of loading a steel-concrete beam by a concentrated force, it was possible to obtain the same step of the stops along the length of the beam, which, in turn, allows a more rational use of the structure's materials. This is reflected in the reduction of the required amount of materials and the reduction in the labor costs required for the manufacture and operation of the structures under consideration. The proposed algorithm was constructed to include the possibility of extending it to other structures and their operational conditions.

An approach to solving the set tasks is universal. This article shows that, after some refinement, the methodology outlined in [22], could be extended to a different loading

technique. Hence, it follows that the procedure makes it possible to apply a given approach for any loading technique, taking into consideration a combination of various loads. The versatility of the procedure is also that the proposed approach makes it possible to calculate steel-concrete beams with flexible anchors. To this end, the algorithm must take into consideration their malleability.

The algorithm reported in this paper is applicable for composite sections made from steel and concrete (in steel-concrete beams). It is not applicable to the reinforced concrete beams as there are no rigid stops in such beams.

New types of materials are now becoming more common. These include different polymers, fiber concrete, other artificial materials. The properties of such materials have their own features, which, of course, need to be taken into consideration. The possibility of applying a given algorithm to such materials was not considered although the proposed approach could certainly be used in the calculation.

Many structures operate under special conditions. These include an aggressive environment, high fire hazard, shock loads, earthquake-prone areas, etc. In such cases, measures should be taken to protect the structures in operation. Tools to protect against such hazards are known and should be applied regardless of the type and degree of structure optimization.

All the above allows us to formulate possible directions for the advancement of the current study. This primarily implies the application of the proposed algorithm for the calculation of steel-concrete beams with flexible anchors, taking into consideration their malleability, as well as the use of the calculation procedure for structures made from other materials.

8. Conclusions

1. The calculation of steel-concrete beams has been performed on the basis of the predefined mechanical characteristics of materials. The external load is 5 kN/m, the length of the beam is 2 m. The size of the cross-sections of the concrete and steel sheet are known. The calculation involved the action of an evenly distributed external load. We obtained the same step of the stops along the length of the beam, which makes it possible to optimize the structure of the steel-concrete beam.

2. A numerical experiment has been conducted, which demonstrated that the magnitudes of stresses coincide with the estimated values. Across the entire length of the beam, the discrepancy in the results does not exceed 15 %, which confirms the validity of our study.

References

- Xing, Y., Han, Q., Xu, J., Guo, Q., Wang, Y. (2016). Experimental and numerical study on static behavior of elastic concrete-steel composite beams. *Journal of Constructional Steel Research*, 123, 79–92. doi: <https://doi.org/10.1016/j.jcsr.2016.04.023>
- Patil, S. P., Sangle, K. K. (2016). Tests of steel fibre reinforced concrete beams under predominant torsion. *Journal of Building Engineering*, 6, 157–162. doi: <https://doi.org/10.1016/j.jobbe.2016.02.004>
- Vandolovskiy, S. S., Kostyuk, T. O., Rachkovskiy, O. V., Plakhotnikova, I. A. (2018). Technology of creation of steel fiber concrete with high strength to stretchings. *Scientific Works of Kharkiv National Air Force University*, 2 (56), 126–131. doi: <https://doi.org/10.30748/zhups.2018.56.18>
- DBN V.2.6-160:2010. *Stalezalizobetonni konstruktsiyi* (2011). Kyiv: Minrekhionbud Ukrainy, 93.
- TKP EN 1994-1-1:2009 (02250). Eurocode 4: Проектирование сталежелезобетонных конструкций. Ч Design of composite steel and concrete structures Part 1-1. General rules and rules for buildings (2010). Minsk: Minstroyarhitektury, 95.
- DSTU B V.2.6-216:2016. *Rozrakhunok i konstruiuvannya ziednuvalnykh elementiv stale zalizobetonnykh konstruktsiy* (2016). Kyiv: Ministerstvo rehionalnoho rozvytku, budivnytstva ta zhytlovo-komunalnoho hospodarstva Ukrainy, 40.
- Hsiao, P.-C., Lehman, D. E., Roeder, C. W. (2012). Improved analytical model for special concentrically braced frames. *Journal of Constructional Steel Research*, 73, 80–94. doi: <https://doi.org/10.1016/j.jcsr.2012.01.010>
- Mahmoud, A. M. (2016). Finite element modeling of steel concrete beam considering double composite action. *Ain Shams Engineering Journal*, 7 (1), 73–88. doi: <https://doi.org/10.1016/j.asej.2015.03.012>
- Luan, N. K., Bakhshi, H., Ronagh, H. R., Barkhordari, M. A., Amiri, G. G. (2011). Analytical solutions for the in-plane behavior of composite steel/concrete beams with partial shear interaction. *Asian Journal of Civil Engineering*, 12 (6), 751–771.
- Medvedev, V. N., Semeniuk, S. D. (2016). Durability and deformability of braced bending elements with external sheet reinforcement. *Magazine of Civil Engineering*, 3 (63), 3–15. doi: <https://doi.org/10.5862/mce.63.1>
- Zamaliyev, F. S. (2018). Numerical and full-scale experiments of prestressed hybrid reinforced concrete-steel beams. *Vestnik MGSU*, 13 (3 (114)), 309–321. doi: <https://doi.org/10.22227/1997-0935.2018.3.309-321>
- Rakhmonov, A. D., Solov ov, N. P., Pozdeev, V. M. (2014). Computer modeling for investigating the stress-strain state of beams with hybrid reinforcement. *Vestnik MGSU*, 1, 187–195. doi: <https://doi.org/10.22227/1997-0935.2014.1.187-195>
- Utkin, V. A. (2010). The regulation of the neutral axis position when designing sections of steel reinforced concrete span structures. *Vestnik Sibirskoy gosudarstvennoy avtomobil'no-dorozhnoy akademii*, 4 (18), 55–60.
- Storozhenko, L. I., Lapenko, O. I., Horb, O. H. (2010). Konstruktsiyi zalizobetonnykh perekryttiv po profilnomu nastylu iz zabezpechenniam sumisnoi roboty betonu i stali za dopomohoiu skleivuvannya. *Visnyk Natsionalnoho universytetu "Lvivska politekhnika"*, 662, 360–365.

15. Torkatyuk, V. I., Zolotova, N. M., Mel'man, V. A. (2003). Ispol'zovanie akrilovykh kleev dlya soedineniya betonnykh i zhelezobetonnykh konstruktsiy. *Municipal economy of cities*, 51, 61–68.
16. Storozhenko, L. I., Krupchenko, O. A. (2010). Stalezalizobetonni balky iz zalizobetonnykh verkhnim poiasom. *Visnyk Natsionalnoho universytetu "Lvivska politekhnika"*, 662, 354–360.
17. Bobalo, T. V., Blikharskyi, Z. Ya., Ilnytskyi, B. M., Kramarchuk, A. P. (2011). Osoblyvosti roboty stalebetonnykh balok armovanykh sterzhnevoiu vysokomitsnoiu armaturoiu riznykh klasiv. *Visnyk Natsionalnoho universytetu "Lvivska politekhnika"*, 697, 35–48.
18. Vahnenko, P. F., Hilobok, V. G., Andreyko, N. T., Yarovoy, M. L. (1987). *Raschet i konstruirovaniye chastey zhilykh i obshchestvennykh zdaniy*. Kyiv: Budlvel'nik, 424.
19. Ying, H., Huawei, P., Xueyou, Q., Jun, P., Xiancun, L., Qiyun, P., Bao, L. (2017). Performance of Reinforced Concrete Beams Retrofitted by a Direct-Shear Anchorage Retrofitting System. *Procedia Engineering*, 210, 132–140. doi: <https://doi.org/10.1016/j.proeng.2017.11.058>
20. John, A. T., Nwankwo, E., Orumu, S. T., Osuji, S. O. (2019). Structural Performance of Externally Strengthened Rectangular Reinforced Concrete Beams by Glued Steel Plate. *European Journal of Engineering Research and Science*, 4 (9), 101–106. doi: <https://doi.org/10.24018/ejers.2019.4.9.1480>
21. Shkromada, O., Paliy, A., Nechyporenko, O., Naumenko, O., Nechyporenko, V., Burlaka, O. et. al. (2019). Improvement of functional performance of concrete in livestock buildings through the use of complex admixtures. *Eastern-European Journal of Enterprise Technologies*, 5 (6 (101)), 14–23. doi: <https://doi.org/10.15587/1729-4061.2019.179177>
22. Petrov, A., Pavliuchenkov, M., Nanka, A., Paliy, A. (2019). Construction of an algorithm for the selection of rigid stops in steel concrete beams. *Eastern-European Journal of Enterprise Technologies*, 1 (7 (97)), 41–49. doi: <https://doi.org/10.15587/1729-4061.2019.155469>
23. Petrov, A. N., Kobzeva, E. N., Krasnyuk, A. G. (2015). Vybory optimal'nykh parametrov stalebetonnykh balok. *Materialy III mizhnarodnoi naukovo-praktychnoi konferentsiyi*. Kharkiv-Krasnyi Lyman, 330–336.