

The development of technology and drying equipment tackles a triune task: to intensify drying processes, to save energy, to ensure that proper product quality is achieved. This issue is resolved by modern advancements by supplying thermal energy throughout the entire sample volume. The simplest option among the known techniques is to heat wet raw materials by passing an electric current directly, with an external blowing by a hot heat carrier.

This paper reports an experimental study of the combined process of drying apple raw materials using direct electric heating.

The influence of control factors such as the field intensity and a heat carrier temperature on the kinetic parameters of the process has been determined, namely: the duration of the combined drying of apples, the rate of moisture removal, and a change in the temperature of the sample.

It was established that the application of additional electric heating with an electric field intensity of 20–40 V/cm during convective drying with a heat carrier temperature of 25–55 °C reduces the duration of apple dehydration by 3–5 times.

Permissible limits for changing the combinations of basic technological parameters have been determined, as well as the rational modes for treating raw materials in order to ensure the predefined quality of finished products. Such combinations of technological parameters of heating, in particular the intensity of the electric field and air in the dryer, are 30 V/cm+40 °C, and 25 V/cm+55 °C.

The energy parameters of the proposed combined technique of drying apple raw materials have been determined. It was established that the specific energy consumption for the removal of 1 kg of moisture at direct electric heating is 2,350–2,400 kJ/kg (0.66 kWh/kg).

The study performed could provide a prerequisite for devising an energy-efficient technique for the combined drying of fruit and vegetable raw materials using direct electric heating

Keywords: apples, drying, moisture content, direct electric heating, electric field intensity, energy saving

Received date 05.12.2020

Accepted date 30.01.2021

Published date 19.02.2021

DETERMINING THE KINETIC AND ENERGY PARAMETERS FOR A COMBINED TECHNIQUE OF DRYING APPLE RAW MATERIALS USING DIRECT ELECTRIC HEATING

O. Savoiskyi

Senior Lecturer*

E-mail: o.savoiskyi@gmail.com

V. Yakovliev

PhD, Professor*

E-mail: vfyakov@gmail.com

V. Sirenko

PhD, Associate Professor*

E-mail: snaumen105@ukr.net

*Department of Energy and Electrical Engineering Systems
Sumy National Agrarian University
Herasyma Kondratieva str., 160,
Sumy, Ukraine, 40021

Copyright © 2021, O. Savoiskyi, V. Yakovliev, V. Sirenko

This is an open access article under the CC BY license

(<http://creativecommons.org/licenses/by/4.0>)

1. Introduction

In providing the population of the Earth with food, the fruits and vegetables that are rich in vitamins play an important role. With one or two-time harvesting per year, the consumer properties of produce are ensured by long-term storage in fresh form or when canned. One of the oldest and most reliable techniques of conservation is drying. When moisture is removed, the activity of microorganisms stops, and nutrients are saved [1].

In the technology of moisture removal, the main energy process is thermal drying. Review papers [2–4] often mention drying techniques in the historical aspect along with different sources of thermal energy and appropriate methods of supplying heat to the dried material. The simplest classification is to divide them into natural drying and the drying involving special energy sources.

Natural drying does not require any energy costs but is characterized by the long-term process of moisture removal and the large areas used to arrange the related equipment.

The desire to improve productivity led to the development of various techniques for supplying thermal energy to the dried material, which can be conditionally divided into the surface (convective, conductive) techniques and volumetric ones (acoustic, microwave, IR, sublimation, etc.). Analysis shows that existing methods often do not meet the quality requirements for the finished product, the equipment needed is costly, and they are energy-intensive and ineffective. Therefore, it is a relevant task for the processing industry to conduct scientific research aimed at upgrading existing and developing new energy-efficient techniques to dry fruit and vegetable raw materials.

2. Literature review and problem statement

The information, given in paper [5], about the most common types of dryers for processing agricultural products shows that in most cases the necessary quality of dehydrated products and acceptable process duration are ensured. However, the specific energy cost of removing 1 kg of moisture from the material is 2–3 times higher than the theoretical value of the specific heat of vapor formation, 2,550 kJ/kg (0.71 kWh/kg).

Convective drying plants are used to process dispersed products; they consume 1.6–2.5 kWh of energy per 1 kg of evaporated moisture. Thermoradation ones, for sheet materials, use 1.5–2.5 kWh/kg. The drying of thick-sheet objects, for example, timber, by using high-frequency currents requires energy consumption of 2.5–5 kWh per 1 kg of removed moisture at the high cost of equipment. A small amount of heated water is consumed directly for drying by sublimation to thaw a frozen product but the total energy cost, the price of refrigeration and vacuum equipment is much greater than that in other techniques [5–7].

In order to improve and reduce the energy intensity of the process, increased attention is paid to combined drying methods, which include several mechanisms for removing moisture from the processed product [2, 8–11]. However, it is not possible to achieve a significant reduction in specific energy costs for the implementation of the process in these cases.

The authors of works [12–17] consider, among the alternative drying techniques, preliminary heating of wet materials by the direct passage of electric current as a technique of one-stage removal of the volumetric joule heat from dried objects with the highest efficiency. Thus, in [12], the peeled apples, cut into 10×10 mm cubes, were immersed in 65 % sucrose-filled cylindrical stainless-steel tanks, with a plastic bottom, and connected by two electrodes to the generator. Next, the osmotic solution was heated for 90 minutes by passing an AC with a frequency of 60 Hz and a voltage of 100 V, creating an electric field with a voltage of 13 V/cm. The results of the reported experiments showed that ohmic heating significantly increases and accelerates the loss of moisture from apple solids compared to control samples. However, the cited work does not analyze how a change in the intensity of the electric field of ohmic heating would affect the course of the dehydration process. In addition, the use of solutions for preprocessing greatly complicates the manufacturing process.

The same approach was highlighted in paper [13]; however, it involved equipment with a modified design, compared to work [12]. The authors of [13] found that ohmic heating enhances mass exchange during the osmotic dehydration of apple cubes. The findings are explained by the ability of ohmic heating to effectively penetrate cell membranes and cause significant changes in the apple structure, reflected by an increase in the electrical conductivity of the tissue. However, similar to work [12], the study was carried out only at one value of the electric field intensity of 60 V/cm. It is also not clear how the possible emergence of a layer of sugar at the surface of the fruit would affect, as a result of using syrup in the process of ohmic heating, the resulting quality of the finished product.

Paper [14] considers the convective drying process, under which the apples cut into plates of 15×15×5 mm were pre-treated with ohmic heating for 1 minute at an electric field intensity of 20–40 V/cm. Compared to the control group, there was a 24, 35, and 29 % decrease in drying time for samples treated at an

electric field intensity of 20, 30, and 40 V/cm, respectively. In addition, processed apples retained their correct shape much better and demonstrated better organoleptic performance. However, during the research, sliced apples for pre-treatment were poured with water. Therefore, the question arises regarding the preservation of nutrients and vitamins in raw materials as a result of the mass exchange with an aqueous solution in the process of ohmic heating.

In [15], the fruits of sweet potatoes, cut into 10×10×5 mm plates, were heated, between two titanium electrodes, to a set temperature with an alternating electric current of 60 Hz and field intensity of 50, 70, and 90 V/cm. Immediately after heating, the resulting samples were placed in a vacuum sublimation drying chamber. The experiments showed that preheating samples with electric current reduces their dehydration time by 22–24 %. However, the application of ohmic heating at the specified values of the electric field intensity leads to significant heating of the raw materials, which would adversely affect the quality of the finished product. In addition, the use of equipment for vacuum sublimation drying leads to a significant cost of the technical means.

The authors of [16] investigated the effect of preliminary ohmic heating on the convective drying of potato tissues by monopolar pulses of almost rectangular shape with an intensity of up to 500 V/cm. It was found that at the electric field intensity above 70 V/cm, due to the excess applied power, significant damage to the material tissues occurs. Reducing the electrical potential of pre-ohmic heating to 50 V/cm reduces the temperature of potato drying by about 20 °C. However, the application of converters to generate pulses of the predefined shape greatly complicates the design of drying equipment and increases its cost.

A comparative study of the influence of preliminary chemical, microwave, and pulse electrical treatment on the convective drying and quality of raisins was carried out in work [17]. The study results indicate a significant increase in the drying rate due to the pre-treatment using a pulsating electric field (PEF). In addition, the appearance, content of dry soluble substances, and market quality of PEF-processed products were better compared to chemical treatment and control non-treated samples. However, the pulse processing involving PEF is carried out at an electric field intensity of 1 kV/cm. Due to the increased danger to staff, the use of this kind of high-voltage equipment is much more complicated.

The studies reported in [18–21] demonstrate an unambiguous reduction in the processing time when using direct electric heating by the currents of industrial frequency throughout the entire process of the convective drying of fruit raw materials. However, the efficiency of applying the proposed combined drying method depends primarily on the physical and electrical characteristics of objects that are constantly changing in the process of dehydration and depends both on the moisture content and the temperature of the product being processed.

The analyzed combined technologies of drying raw materials with the use of direct electric heating demonstrated the positive effect of utilizing internal electric joule heat. At the same time, most often this type of heating is used only at the pre-treatment stage without an in-depth study into the kinetics of dehydration and physical processes occurring inside a biological object during drying. Taking into consideration the complexity of these processes, it becomes necessary to establish the dependences of technological parameters on the properties of dried objects throughout the entire drying process.

3. The aim and objectives of the study

The aim of this study is to determine the kinetic and energy parameters of the combined technique for drying apple raw materials using direct electric heating in order to reduce the energy cost of the dehydration process while ensuring the required quality of the finished product.

To accomplish the aim, the following tasks have been set:

- to investigate the process of the combined technique for drying apple raw materials using direct electric heating and determine the dependence of the main kinetic parameters of the process at different values of the electric field intensity and the temperature of the heat carrier in a drying plant;

- to substantiate the rational process parameters, in particular, the maximum temperature of the heat carrier in a drying chamber, as well as the maximum intensity values of the electric field in direct electric heating, ensuring the proper quality of the finished product;

- to determine specific energy costs for the removal of 1 kg of moisture during the direct electric heating of raw materials in the process of the combined drying of apple raw materials.

4. Materials and methods to study the kinetic and energetic parameters of the combined drying of apple raw materials

4.1. Materials, equipment, and devices used in the experimental study

Apples of the early summer and summer ripening varieties “Red Mac”, “Mantet” and “Helios”, grown in the Sumy region of Ukraine, were chosen as the objects of our research.

We studied the drying process using the designed experimental installation whose schematic is shown in Fig. 1.

The installation consists of a convective drying chamber of type 1, SNOL-2.5 (Ukraine). The air temperature inside the drying chamber was set and controlled by automatic control unit 6.

The air temperature in the chamber and inside the dried samples was determined by installed thermocouples 12, the type of THA (chrome-alumel) (China), with the thermo-electrodes, 0.2 mm in diameter, connected to temperature indicator (electronic multimeter) 13, the type of VC61A (China).

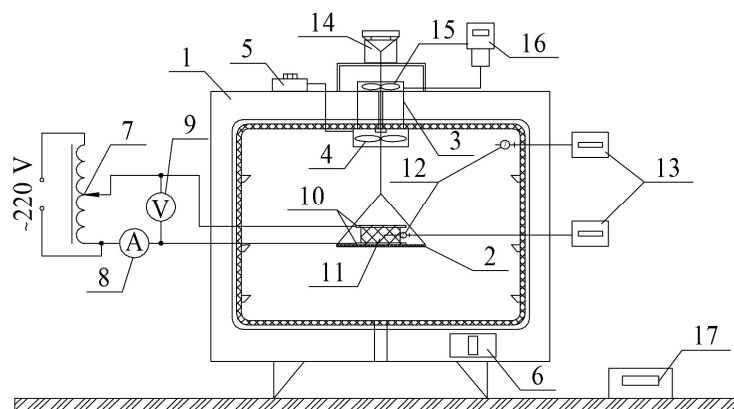

Fig. 1. Scheme of experimental installation: 1 – convective type dryer; 2 – mesh pallet; 3 – ventilation tubes; 4 – fan; 5 – fan speed control unit; 6 – air temperature control unit in the chamber; 7 – laboratory autotransformer; 8 – laboratory milliammeter; 9 – laboratory voltmeter; 10 – mesh electrodes for direct electric heating; 11 – sample under study; 12 – thermocouples; 13 – temperature indicators; 14 – electronic scales; 15 – anemometer impeller; 16 – anemometer; 17 – timer

We determined the mass of samples 11 at mesh pallet 2, suspended to the sensing element of electronic scales 14, the type of MH-200 (China), with a measuring accuracy of up to 0.01 g.

The heat carrier speed in the dryer was provided by axial fan 4, controlled by control unit 5, when changing the voltage of the fan. The airspeed measurements were carried out by installing 3 impellers 15 of electronic anemometer 16, the type of Flus ET-965 (China), in the ventilation tubes.

Direct electric heating of samples was enabled by the system of mesh electrodes 10, connected, through laboratory autotransformer 7, the type of LATR-2,5 (Ukraine), to the AC network of industrial frequency, 50 Hz, and a voltage of 220 V. In order to prevent the oxidation and negative impact on the dried product, we used electrodes made of food stainless steel, grade 08Kh18N10T (Ukraine).

The heating power was controlled by a change in the output voltage of laboratory autotransformer 7. To control the electrical parameters of heating, as well as to determine the electrical resistance of samples by a voltmeter-ammeter method, laboratory voltmeter 9, the type of D5081 (Ukraine), and milliammeter 8, the type of E536 (Ukraine), were also included in the electric circuit.

Time intervals were recorded by electronic timer 17 (Ukraine).

4.2. Research methodology

Pre-prepared apples were cut into disks with a height of 0.005 m and a diameter of 0.028 m.

The samples were put between the mesh electrodes and placed inside the dryer on a mesh tray suspended to a sensing element of the electronic scales. Next, the voltage of the corresponding value with a frequency of 50 Hz was supplied to the electrodes through the LATR. The heat carrier velocity in the dryer was 0.2 m/s; it was maintained constant throughout the drying time.

The experiments were carried out under the predefined temperature regimes in the dryer of 25–55 °C and at the intensity of the electric field on electrodes of 20–40 V/cm.

At the specified intervals, the following measurements were carried out: the mass of a sample; the temperature inside a sample; the current magnitude flowing through a sample.

Time intervals were set depending on the rate of change in the controlled parameters and the duration of the entire drying process. Each experiment was repeated three times.

The resulting array of data was exported to the Excel spreadsheet editor where we calculated the energy costs, moisture content, as well as sample drying rate.

The current moisture content of samples (the humidity calculated relative to the mass of perfect dry matter of the material) during the experiments was determined from the expression given in [22, 23]:

$$X_i = \frac{M_i - M_{abs}}{M_{abs}}, \quad (1)$$

where X_i is the current moisture content of the material, kg/kg; M_i is the current mass of a sample, kg; M_{abs} is the mass of perfect dry insoluble and soluble minerals in a sample, kg.

Energy consumption during the direct electric heating was calculated from the following expression:

$$W_{OH} = \sum U_{OH} I_i \tau_i, \tag{2}$$

where W_{OH} is the energy spent on the direct electric heating of samples, J; U_{OH} is the voltage on electrodes, V; I_i is the average value of the current force over an interval of time, A; τ_i is the time, s.

The share of the flux of the convective energy component that enters raw materials during the peak period, when the heat carrier temperature becomes higher than the sample temperature, equals, based on the heat transfer equation from [24]:

$$q_k = \alpha F \Delta t, \tag{3}$$

where α is the heat transfer coefficient from air to hard surface; F is the air exchange surface, m^2 ; Δt is the average difference in the temperature of air and sample during the after-peak period, $^{\circ}C$.

The heat exchange surface is:

$$F = \frac{2\pi d^2}{4} + \pi dh, \tag{4}$$

where d, h is the diameter and thickness of the sample, m.

The heat transfer coefficient from air to a solid surface is determined from the empirical formula given in [24]:

$$\alpha = 11.6 + 7\sqrt{v_{air}}, \tag{5}$$

where v_{air} is the heat carrier velocity, m/s.

To visualize the results of the research, we used the standard software package Statistica 12.

5. Results of determining the kinetic and energy parameters for the combined drying of apple raw materials

5.1. Results of determining the kinetic parameters for the combined drying of apple raw materials

When we studied the proposed combined drying method, thermal energy was supplied inside the dried apple raw materials in two ways:

- 1) by the direct electric heating whose main controlled parameter is the electric field intensity throughout the thickness of the sample;
- 2) by convective heat and mass transfer.

During the research, it was found that heating with an electric field intensity below 20 V/cm almost does not affect the intensification of the drying process. In this case, when this value exceeds 40 V/cm, there is almost instantaneous heating of the samples accompanied by the boiling of internal moisture and deterioration in the quality of finished products.

Fig. 2–5 show the results of our experimental study into the combined process of drying apples at a heat carrier temperature in the drying chamber of 25–55 $^{\circ}C$ and at an intensity of the direct electric heating field of 20–40 V/cm.

The four series of graphical results of our experiments (Fig. 2–6) reflect changes in four manufacturing parameters depending on the process duration when changing the electric field intensity from 20 to 40 V/cm, namely:

- moisture content (Fig. 2);
- moisture removal rate (Fig. 4);

- the force of current passing through a sample (Fig. 5);
- the sample temperature (Fig. 6).

The influence of a heat carrier’s temperature is registered by changes in parameters in each series in Fig. 2–5.

The most informative is the dependence of the amount of moisture content in apple raw materials on time (Fig. 2) at the different combination of driving forces – the intensity of the electric field and the temperature of the heat carrier.

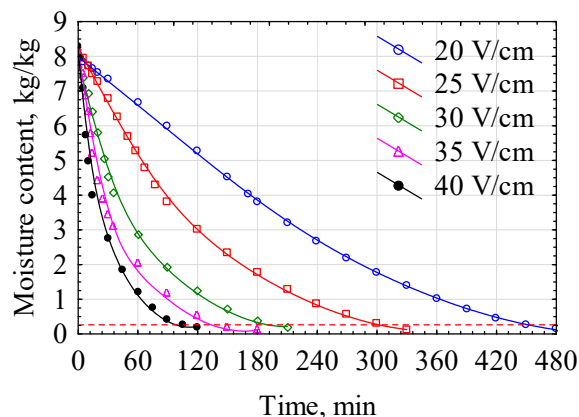

a

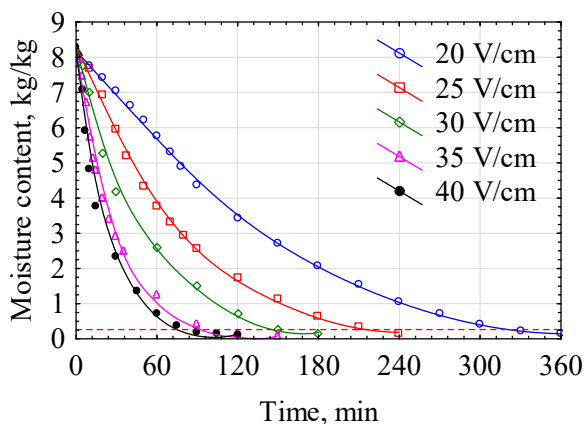

b

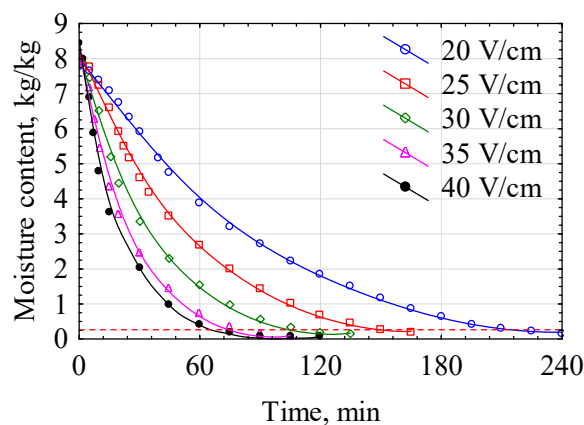

c

Fig. 2. Dependence of moisture content in the drying process at an intensity of the direct electric heating field of 20–40 V/cm and an air temperature in the chamber of: a – 25 $^{\circ}C$; b – 40 $^{\circ}C$; c – 55 $^{\circ}C$

The drying process is completed when the equilibrium moisture content is achieved, which, according to [22, 23], is 18–20 %, which, in terms of solids weight, is 0.25 kg/kg. The intersection point of the curves of drying with the equilibrium horizontal determines the duration of the entire drying process. These data are displayed in the summary chart (Fig. 3).

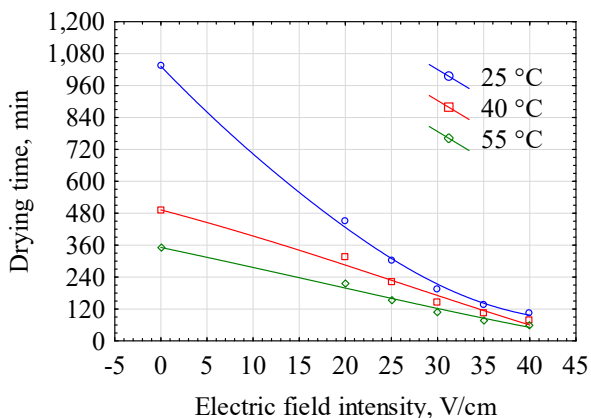

Fig. 3. Dependence of drying time on the intensity of a direct electric heating field at an air temperature in the dryer of 25, 40, and 55 °C

The analysis of drying time data reveals the extent of individual impact exerted by a heat carrier temperature within permissible limits of 25, 40, 55 °C on a decrease in process time. At the electric field intensity of 20, 25, 30 V/cm, the decrease in time is 2.25; 2, and 1.66 times, respectively.

And an increase in the potential from 20 to 30 V/cm at the heat carrier temperatures of 25, 40, 55 °C gives a reduction in time by 2, 2.3, and 2 times, respectively. The greatest effect is observed when comparing the modes of 20 V/cm+25 °C (time, 440 min) and 30 V/cm+55 °C (time, 110 min); the drying time decreased by 4 times.

The duration of drying without the use of direct electric heating (which corresponds to the intensity of 0 V/cm in Fig. 3) at an air temperature of 25 °C is about 18 hours. And, at operating temperatures of air in the chamber of 40 and 55 °C, the processing time is 8.2 and 4.8 hours, which is at least 4 times the duration of drying with additional direct electric heating.

The maximum removal rate of moisture mass (Fig. 4) increases as the intensity of the electric field and the temperature of the heat carrier increase.

In the studied range of field intensity, the value of the maximum drying speed at a heat carrier temperature of 25 °C (Fig. 4, a) is in the range of 0.0065–0.132·10⁻³ kg/min. At the same time, at 40 (Fig. 4, b) and 55 °C (Fig. 4, c), the removal rate increased significantly and amounted to 0.014–0.15·10⁻³ and 0.0255–0.172·10⁻³ kg/min, respectively.

It should also be noted that in all cases, during the time of reaching peak values, 1/3 of the mass of all moisture in the sample is removed.

From the moment of reaching peak values during the entire drying time to the final moisture content of the raw materials, we observe in all modes a constant decrease in the values of the moisture removal rate.

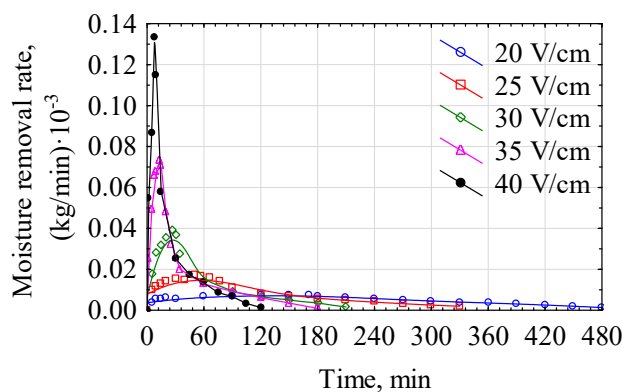

a

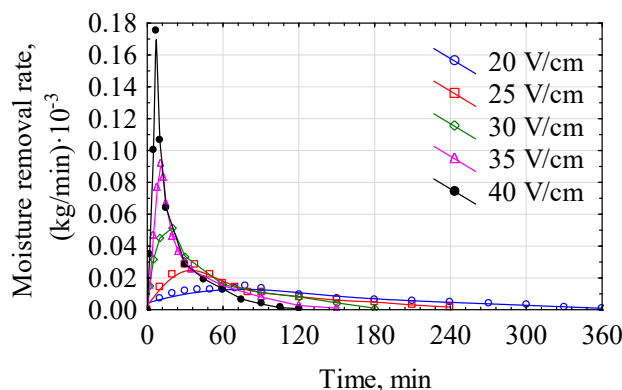

b

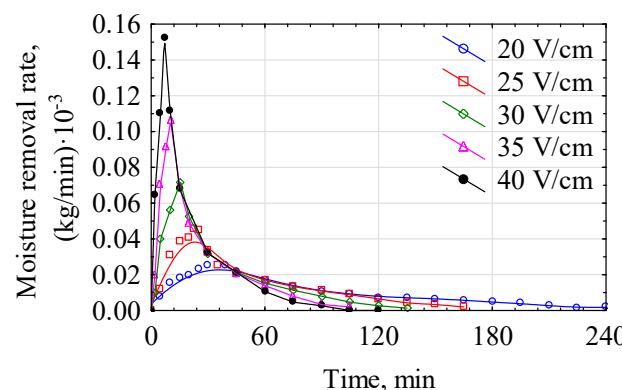

c

Fig. 4. Dependence of the rate of moisture removal during drying at the intensity of a direct electric heating field of 20–40 V/cm and at an air temperature in the chamber of: a – 25 °C; b – 40 °C; c – 55 °C

The main parameter that defines the quality of the finished product and the amount of energy spent on moisture evaporation during drying by the proposed method is the amount of electric current passing through the dried material. The analysis of curves (Fig. 5) showed that the peak values of current strength match the maximum values of the moisture removal rate (Fig. 4) and the temperature of the sample (Fig. 6).

The maximum value of the current passing through a sample increases with increasing the intensity of the electric field and the air temperature in the dryer. Thus, at a heat car-

rier temperature of 25 °C (Fig. 5, *a*) and the corresponding intensity of the electric field the maximum current values reached the level of 0.02–0.23 A; at 40 (Fig. 5, *b*) and 55 °C (Fig. 5, *c*) – 0.06–0.29 and 0.1–0.32 A, respectively.

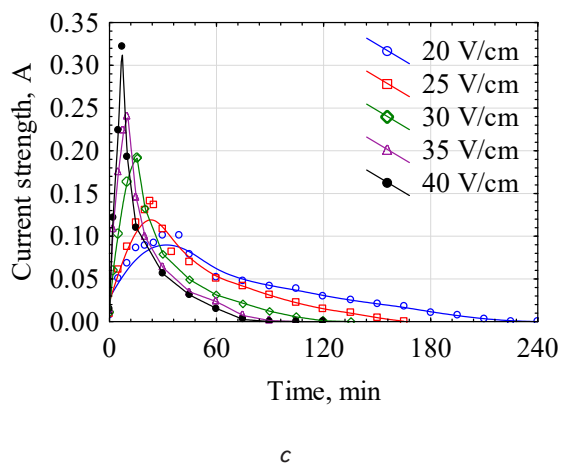
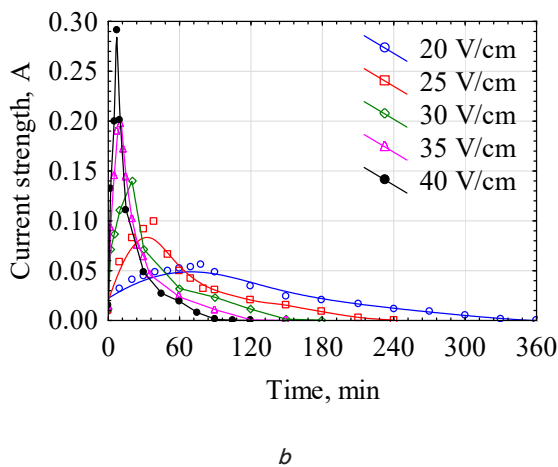
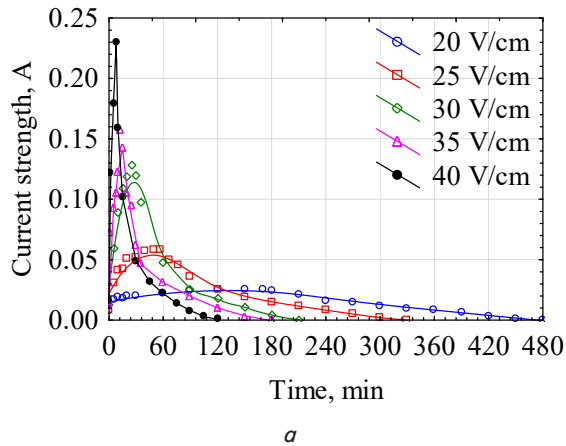

Fig. 5. Dependence of the current strength passing through a sample during drying at an intensity of the field of direct electric heating of 20–40 V/cm and at an air temperature in the chamber of: *a* – 25 °C; *b* – 40 °C; *c* – 55 °C

It should be noted that with an increase in temperature in the dryer, the difference between the peak values of maximum currents, with an increase in the intensity of the electric field, decreases. At an air temperature of 25 °C, with an increase

in the voltage gradient on electrodes, the maximum current values increased by 11.5 times, and at 40 and 55 °C – by 4.8 and 3 times, respectively.

Our analysis of temperature curves (Fig. 6) shows that the maximum temperature value of the samples during drying increases with an increase in the voltage gradient on electrodes and a heat carrier temperature. In addition, in proportion to drying, the temperature of the samples gradually decreases and becomes lower than the heat carrier temperature by about 5 °C.

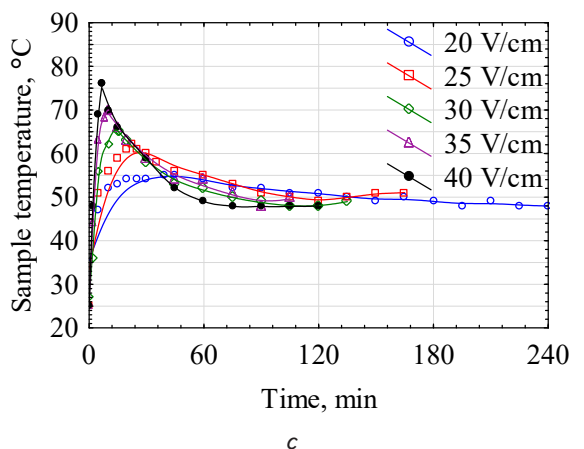
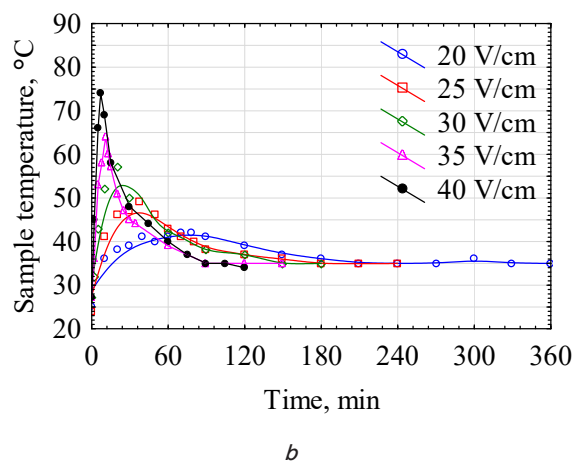
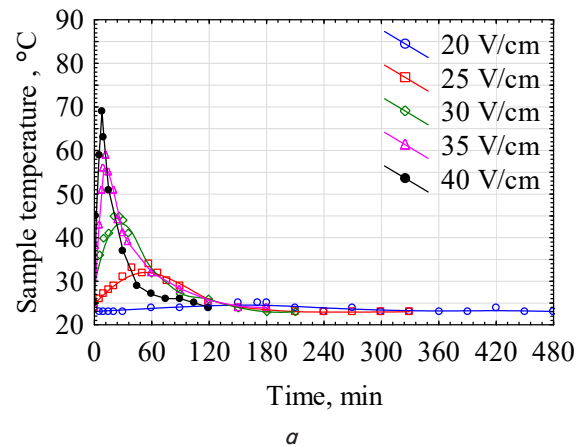

Fig. 6. Dependence of the sample temperature in the drying process at an intensity of the field of direct electric heating of 20–40 V/cm and at an air temperature in the chamber of: *a* – 25 °C; *b* – 40 °C; *c* – 55 °C

As the electric field intensity increases, the effect of the temperature of the drying agent on the maximum temperature of the samples decreases. With an increase in the intensity from 20 to 40 V/cm, the value of the maximum temperature of apples at an air temperature of 25 °C increased by 2.8 times, and at the temperatures of 40 and 55 °C – by 1.8 and 1.4 times, respectively.

5.2. Substantiation of the rational manufacturing parameters for the combined process of drying apple raw materials

A significant increase in the temperature of raw materials leads to a change in the chemical composition, namely, a decrease in the content of nutrients, vitamins, and minerals in the resulting product. Taking into consideration the requirements for the quality of finished products, the upper limit of heating the apple raw materials to 55–60 °C [1, 25] is set.

The maximum temperature of samples during drying at different combinations of temperature in the dryer and the intensity of the electric field of direct heating were determined by the peak values from graphical dependences in Fig. 6. The results of our measurements are given in Table 1. Over time, the values of the maximum temperature coincide with the peak values of electric current in the samples (Fig. 5).

Table 1

Maximum temperature of samples during drying at different combinations of temperature in the dryer and the intensity of the direct heating electric field

$t_{air}, ^\circ C$ \ E, V/cm	20	25	30	35	40
25	27	34	45	62	69
40	42	49	57*	64	74
55	55	59*	64	69	76

The use of combinations that lead to overheating of raw materials above 60 °C is unacceptable. In addition, a significant excess of the sample temperature above the air temperature in the dryer would lead to an unjustified increase in the specific energy consumption to remove 1 kg of moisture. Based on the above, the combinations marked with an asterisk in Table 1 are optimal for processing raw materials.

It should be noted that the use of modes with an intensity above 30 V/cm does not lead to a significant intensification of the process but leads to the significant heating of the raw materials.

5.3. Determining energy parameters for the combined process of drying apple raw materials

We determined energy fluxes from convective heat exchange and direct electric heating at the average temperature values of samples (Fig. 6) and current values (Fig. 5). The calculation results for the established ranges of the electric field intensity of 20–40 V/cm and at an air temperature of 25–55 °C are given in Table 2.

The ratio of the electrical and convective components of heat fluxes during drying in the after-peak period accepts a value of 2.8–4.2.

Moreover, during peak loads, the sample gives the resulting energy back to the heat carrier. With the final removal of moisture, the amount of energy from the direct electric

heating is 3–4 times higher than the convective component, which indicates the principal role of electric heating.

Table 2

Thermal heating fluxes to one sample from direct electric heating (q_e , W) and convection (q_k , W)

$t_{air}, ^\circ C$ \ E, V/cm	20		30		40	
	q_k	q_e	q_k	q_e	q_k	q_e
25	0.0282	0.1012	0.113	0.3103	0.071	0.2120
40	0.0846	0.2505	0.1021	0.2523	0.1702	0.5261
55	0.0946	0.3504	0.0846	0.3707	0.1421	0.6217

The calculated values of the magnitude of specific energy consumption (Fig. 7) at direct electric heating for the removal of 1 kg of moisture are close to the theoretical values for the specific energy of vaporization at appropriate temperatures [24]. In the studied range of electric field intensity, the energy consumption for direct electric heating ranges from 1,900 to 2,550 kJ/kg (0.53–0.71 kWh/kg) at the appropriate air temperature in the drying chamber.

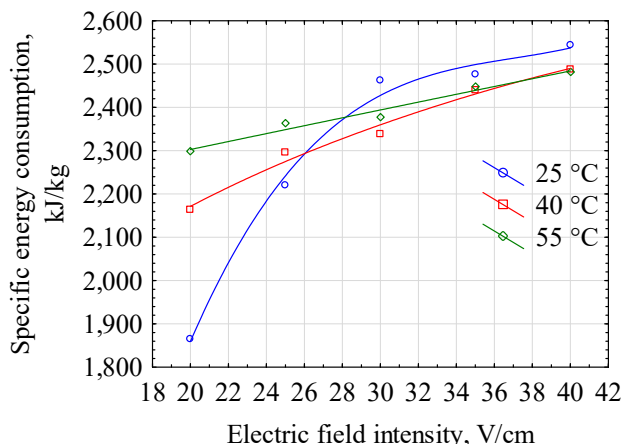

Fig. 7. Dependences of the specific energy consumption to remove 1 kilogram of moisture on the intensity of the electric field at an air temperature in the drying chamber of 25, 40, and 55 °C

It follows from Fig. 7 that the same nature of dependences for specific electrical costs for the evaporation of 1 kg of moisture on the intensity of the electric field starts from 26–30 V/cm. At lower potential values, the share of energy coming from direct electric heating becomes much smaller while the convective component of energy supply becomes more significant.

6. Discussion of results of studying the kinetic and energy parameters of the combined drying of apple raw materials

The results of our research are a continuation of the experiments initiated on the combined technique of energy supply to dried apple raw materials reported in works [18–21].

In objects of plant origin, the amount of moisture in the free state is insignificant. In most cases, it is always related to components or is inside the cells, surrounded by their shells [26]. When raw materials are heated during drying by

passing an alternating electric current through them, at the same time as its temperature rises, the phenomenon of electroplasmolysis occurs [25, 27, 28]. As a result, the cytoplasm membranes of the cells are irritated, which facilitates the movement of moisture from the inner layers to the surface. This explains a significant reduction in the duration of the apple drying process by the proposed combined technique.

The analysis of drying curves (Fig. 2) demonstrates that the use of the direct electric heating of raw materials could reduce the dehydration time by 3–5 times compared to traditional convective drying (Fig. 3). As the intensity of the electric field of direct heating increases, the drying time decreases, and the effect of the heat carrier temperature on the dehydration rate is minimized.

Direct electric heating dramatically changes the course of the dehydration process. Drying by the proposed combined method could be divided into two main periods: the growing and the falling drying speed periods (Fig. 4). In this case, during the period of increasing drying rate, 30–35 % of the moisture mass is removed, and the period of constant speed, characteristic of the convective dehydration process, is absent [24].

This is due to the increase in the temperature of samples at the beginning of the process (Fig. 6) as a result of a sharp increase in the strength of the electric current (Fig. 5), which entails an increase in the amount of joule heat released. The increase in the value of current strength passing through the sample is explained by a sharp drop in its electrical resistance due to an increase in the juice extraction from raw materials as a result of their heating and the phenomenon of electroplasmolysis [25, 27, 28].

The data from Table 1 make it possible to determine the rational modes of drying apple raw materials by the proposed technique. Taking into consideration the requirements for the quality of finished products, the most rational combinations of technological parameters for heating are 30 V/cm +40 °C and 25 V/cm +55 °C. Under these drying modes, the temperature of raw materials does not rise above 59 °C. And the duration of the dehydration process is 145 and 155 minutes, respectively, which is 70.5 and 46.1 % less compared to convective drying at the specified heat carrier temperatures.

For the established operating modes of the dryer, the specific energy consumption for removing 1 kg of moisture at the direct electric heating is 2,350–2,400 kJ/kg (0.66 kWh/kg). The obtained results are close enough to the theoretical values of the specific energy of vapor formation at appropriate heat carrier temperatures [5, 7], which indicates the energy efficiency of this dehydration technique. The most common industrial convective-type installations consume 1.6–2.5 kWh of energy to remove 1 kg of moisture, which is several times larger than the obtained values for the proposed drying technique.

A special feature of the proposed drying technique, compared to others, is the simultaneous direct electric heating and convective heat supply throughout the entire dehydration cycle.

The study reported here proves the expediency of using direct electric heating in the process of drying wet apple raw materials. The application of this type of additional heating could provide intensive and energy-efficient processing modes while maintaining the predefined quality of finished products.

One of the main parameters that determines the intensity of moisture removal from the material is the heat carrier velocity in the dryer. The value of this parameter under the conditions of our experiment was limited to one value of 0.2 m/s. Therefore, it is of practical interest to study the kinetics of the drying process at higher values of the heat carrier velocity. Increasing the speed at a convective heat supply would certainly intensify the drying of raw materials; however, only experimental study could show how this would affect the process of combined heating.

The study limitations include the fact that the study was carried out only for one type of fruit. However, the comparison of the electrophysical parameters of raw materials, reported in works [15, 16, 19, 21, 30, 31], which determine the possibility of using direct electric heating, allows us to assume the possibility of using the proposed technique for drying other types of fruits and vegetables.

A further stage of the study is the development of a technical means for the combined drying of fruit and vegetable raw materials using direct electric heating based on the obtained data. The main difficulties in solving this task may be the lack of data on the electrophysical parameters of some types of fruits in the literature, which are necessary to determine the optimal modes of raw material processing. However, this issue could be resolved by conducting additional experimental studies.

7. Conclusions

1. We have experimentally established the kinetic dependences of the moisture content, the rate of moisture removal, and the temperature of apple samples in the ranges of the electric field intensity of 20–40 V/cm and at a heat carrier temperature in the drying plant of 25–55 °C.

2. The rational modes for drying apple raw materials by the proposed combined technique have been determined, at which excessive heating of products above the permissible temperature of 60 °C is excluded. Such combinations of technological parameters of heating include, in particular, the intensity of the electric field and air in the dryer: 30 V/cm+40 °C, and 25 V/cm+55 °C. Using these modes would reduce the duration of dehydration by 70.5 and 46.1 % compared to convective drying at the specified temperatures of the heat carrier.

3. For the established rational operating modes of the dryer, the specific energy consumption for the removal of 1 kg of moisture at direct electric heating is 2,350–2,400 kJ/kg (0.66 kWh/kg).

References

1. Skripnikov, Yu. G. (1988). *Tehnologiya pererabotki plodov i yagod*. Moscow: Agropromizdat, 287.
2. Singham, P., Birwal, P. (2014). Technological revolution in drying of fruit and vegetables. *International Journal of Science and Research (IJSR)*, 3 (10), 705–711. Available at: <https://www.researchgate.net/publication/295616726>
3. Karam, M. C., Petit, J., Zimmer, D., Djantou, E. B., Scher, J. (2016). Effects of drying and grinding in production of fruit and vegetable powders: A review. *Journal of Food Engineering*, 188, 32–49. doi: <https://doi.org/10.1016/j.jfoodeng.2016.05.001>

4. Moses, J. A., Norton, T., Alagusundaram, K., Tiwari, B. K. (2014). Novel drying techniques for the food industry. *Food Engineering Reviews*, 6, 43–55. doi: <https://doi.org/10.1007/s12393-014-9078-7>
5. Lebedev, P. D. (1988). *Raschet i proektirovanie sushil'nyh ustanovok*. Moscow: Gosenergoizdat, 320.
6. Bhatta, S., Janezic, T. S., Ratti, C. (2020). Freeze-Drying of Plant-Based Foods. *Foods*, 9 (1), 87. doi: <https://doi.org/10.3390/foods9010087>
7. Mushtaev, V. I., Ul'yanov, V. M. (1988). *Sushka dispersnyh materialov*. Moscow: Himiya, 352.
8. Onwude, D., Hashim, N., Janius, R., Abdan, K., Chen, G., Oladejo, A. (2017). Non-thermal hybrid drying of fruits and vegetables: A review of current technologies. *Innovative Food Science & Emerging Technologies*, 43, 223–238. doi: <https://doi.org/10.1016/j.ifset.2017.08.010>
9. Zhang, M., Tang, J., Mujumdar, A., Wang, S. (2006). Trends in microwave-related drying of fruits and vegetables. *Trends in Food Science & Technology*, 17 (10), 524–534. doi: <https://doi.org/10.1016/j.tifs.2006.04.011>
10. Dev, S. R., Raghavan, V. G. (2012). Advancements in Drying Techniques for Food, Fiber, and Fuel. *Drying Technology*, 30 (11-12), 1147–1159. doi: <https://doi.org/10.1080/07373937.2012.692747>
11. Ruzhitskaya, N. (2012). The combined vegetable raw material drying processes. *Technology Audit and Production Reserves*, 3 (1 (5)), 23–24. doi: <https://doi.org/10.15587/2312-8372.2012.4731>
12. Moreno, J., Simpson, R., Pizarro, N., Pavez, C., Dorvil, F., Petzold, G., Bugue o, G. (2013). Influence of ohmic heating/osmotic dehydration treatments on polyphenoloxidase inactivation, physical properties and microbial stability of apples (cv. Granny Smith). *Innovative Food Science & Emerging Technologies*, 20, 198–207. doi: <https://doi.org/10.1016/j.ifset.2013.06.006>
13. Allali, H., Marchal, L., Vorobiev, E. (2009). Effect of Blanching by Ohmic Heating on the Osmotic Dehydration Behavior of Apple Cubes. *Drying Technology*, 27 (6), 739–746. doi: <https://doi.org/10.1080/07373930902827965>
14. Isci, A., Kutlu, N., Yilmaz, M. S., Arslan, H., Sakiyan, O. (2018). The effect of ohmic heating pretreatment on drying of apple. *Proceedings of 21th International Drying Symposium*. doi: <https://doi.org/10.4995/ids2018.2018.7375>
15. Zhong, T. (2003). The effect of ohmic heating on vacuum drying rate of sweet potato tissue. *Bioresource Technology*, 87 (3), 215–220. doi: [https://doi.org/10.1016/s0960-8524\(02\)00253-5](https://doi.org/10.1016/s0960-8524(02)00253-5)
16. Lebovka, N. I., Shynkaryk, M. V., Vorobiev, E. (2006). Drying of Potato Tissue Pretreated by Ohmic Heating. *Drying Technology*, 24 (5), 601–608. doi: <https://doi.org/10.1080/07373930600626677>
17. Dev, S. R. S., Padmini, T., Adedeji, A., Gari py, Y., Raghavan, G. S. V. (2008). A Comparative Study on the Effect of Chemical, Microwave, and Pulsed Electric Pretreatments on Convective Drying and Quality of Raisins. *Drying Technology*, 26 (10), 1238–1243. doi: <https://doi.org/10.1080/07373930802307167>
18. Yakovliev, V. F., Savoiskyi, O. Yu., Sirenko, V. F. (2018). Pat. No. 127324 UA. Sposib kombinovanoho sushinnia biolohichnykh ob'ektiv. No. u201802036; declared: 27.02.2018; published: 25.07.2018, Bul. No. 14.
19. Yakovlev, V., Savoiskyi, A. (2018). The use of direct electric heat in a technological process of combined drying. *Visnyk Kharkivskoho natsionalnoho tekhnichnoho universytetu silskoho hospodarstva im. P. Vasylenka. Tekhnichni nauky*, 195, 91–96. Available at: <http://journals.urau.ua/index.php/wissn021/article/view/155625/155171>
20. Savoiskyi, A., Yakovlev, V., Sirenko, V. (2019). Research of the combined drying process of apple raw material of high humidity. *Scientific bulletin of the Tavria State Agrotechnological University*, 9 (1). Available at: <http://oj.tsatu.edu.ua/index.php/visnik/article/view/181/163>
21. Savoiskyi, A., Yakovlev, V., Sirenko, V. (2019). Research of quantity of unit electrical resistance apple raw in the drying process. *Visnyk Kharkivskoho natsionalnoho tekhnichnoho universytetu silskoho hospodarstva imeni Petra Vasylenka. Tekhnichni nauky*, 203, 107–110. Available at: <http://dspace.khntusg.com.ua/handle/123456789/10272>
22. DSTU 8661:2016. Dried fruits. Acceptance rules, methods of testing (2017). Kyiv.
23. ISO 7701:1994. Dried apples – Specification and test methods.
24. Pavlov, K. F., Romankov, P. G., Noskov, A. A. (1987). *Primery i zadachi po kursu protsessov i apparatov himicheskoy tehnologii*. Leningrad: Himiya, 576.
25. Flaumenbaum, B. L., Tanchev, S. S., Grishin, M. A. (1986). *Osnovy konservirovaniya pishchevyh produktov*. Moscow: Agropromizdat, 494.
26. Kretovich, V. L. (1980). *Biohimiya rasteniya*. Moscow: Vysshaya shkola, 445.
27. Ngadi, M., Bazhal, M., Raghavan, V. (2003). Engineering aspects of pulsed electroplasmolysis of vegetable tissues. *Agricultural Engineering International: the CIGR Journal of Scientific Research and Development. Invited Overview Paper*, 5, 1–10. Available at: <https://www.researchgate.net/publication/228700776>
28. Gamli, Ö. (2014). A review of application of pulsed electric field in the production of liquid/semi-liquid food materials. *Advance Research in Agriculture and Veterinary Science*, 1 (2), 54–61. Available at: <https://www.researchgate.net/publication/293783006>
29. Castro, I., Teixeira, J. A., Salengke, S., Sastry, S. K., Vicente, A. A. (2004). Ohmic heating of strawberry products: electrical conductivity measurements and ascorbic acid degradation kinetics. *Innovative Food Science & Emerging Technologies*, 5 (1), 27–36. doi: <https://doi.org/10.1016/j.ifset.2003.11.001>
30. Sarang, S., Sastry, S. K., Knipe, L. (2008). Electrical conductivity of fruits and meats during ohmic heating. *Journal of Food Engineering*, 87 (3), 351–356. doi: <https://doi.org/10.1016/j.jfoodeng.2007.12.012>