

Combined operating process of torque flow pump

V Panchenko¹, V German¹, V Kondus¹, O Ivchenko¹, O Rysnaya²

¹ Sumy State University, 2 Rimsky-Korsakov st., Sumy 40007, Ukraine

² Sumy National Agrarian University, 160 Gerasim Kondratieva st, 40000, Sumy, Ukraine

E-mail: pan_va@ukr.net

Abstract. Due to a simple design and hydraulic passage that is the least susceptible to clogging, torque flow pumps (TFP) of Turo type are the most common pumps used for pumping various hydraulic mixtures. These pumps are referred to vortex pumps, operation of which is accompanied by energy loss and vortex formation resulting in low economic efficiency. Since the TFP is a vortex hydraulic machine, the ratio of the fluid velocity in the free pump passage to the impeller rotational speed ω_{fluid}/ω is an indicator of the TFP efficiency. The higher the value of ω_{fluid} , the more efficient the pump is. The mechanism of the energy transfer in the TFP is caused by both blade and vortex operating process, or a combined operating process. The efficiency of the pump can be improved by increasing the portion of blade operating process. The aim of the study is to improve the efficiency of the TFP of Turo type by modifying the impeller design, to obtain a basic equation of the TFP with a new impeller which has several extended blades, and to study the influence of the impeller geometry on the pump performance experimentally. The study was carried out by analytical and experimental methods. The equation describing the head dependence on the hydraulic passage dimensions of the pump with a new impeller was obtained analytically. This equation can be used to clarify the methodological recommendations for designing the pump. The energy balance in the TFP was analyzed. During the testing on a test rig, the characteristics of the pump were obtained, which confirmed the advantages of using the modified impeller with extended blades resulting in increase of the portion of the blade operating process.

1. Introduction

While selecting equipment for pumping hydraulic mixtures, more and more attention is paid to torque flow pumps (TFP) of Turo type (Fig. 1) [1]. Due to a simple design, high manufacturability and hydraulic passage which is the least susceptible to clogging, torque flow pumps of Turo type are widely used in various industries and agriculture sector for pumping gas-liquid mixtures, abrasive media and liquids contained solid particles.

They are most widely used as a part of pump units of block-modular design (with removable impeller). Therefore, the interest in this type of pumping equipment is not diminished by both pump users and pump designers. The latter is due to the rather complicated operating process of the torque flow pump of Turo type.

The first attempts to describe the operating process of this TFP as a kind of centrifugal pump have proved to be invalid, and the calculation method adopted on this basis did not ensure the design characteristics of the pump. Therefore, in the future, the operating process of a torque flow pump of



Turo type was additionally studied in [2-7] and the method of its designing was refined. The TFP was regarded as a vortex pump. These pumps are characterized by the presence of a "vortex operating process". The fundamental difference between the torque flow pump operating process and those occurring in other types of hydraulic machines is that the pump head (obtained positive effect) is associated with energy losses. In other words, without the occurrence of energy losses in a torque flow pump, the head will not be developed, and theoretically achievable efficiency of the vortex operating process η_{op} cannot be equal to one. Therefore, the formation of vortex in the TFP during its operation leads to a low efficiency. According to previous studies, the torque flow pump of Turo type can provide parameters with an acceptable efficiency ($\eta = 0.45-0.52$) for annular casing within specific speed $n_s = 60-160$, with the optimum efficiency being within the range $n_s = 100-120$ [2,8].

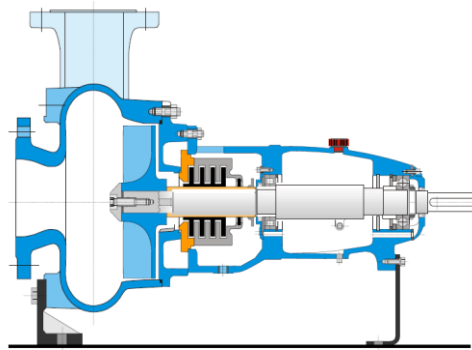

Figure 1. Torque flow pump of Turo type produced by EGGGER.

The flow in the hydraulic passage of the TFP is three-dimensional and cannot be accurately mathematically described. The complexity of the operating process led to the creation of a large number of its hypotheses and models of flow. A detailed analysis of the operating process was performed in [4]. Preferred is a model in which TFP is classified as a vortex hydraulic machine. The fluid flow model is shown in Fig. 2.

In the TFP, fluid particles move in a complex spiral trajectory that passes both the impeller and free passage. In this case, two rotations are superimposed in the free passage of the TFP: the first is around the axis of rotation of the impeller with the angular velocity of fluid rotation ω_{fluid} that is less than the angular velocity of the impeller rotation ω ; the second is around some center of circulation in the meridional cross section of the hydraulic passage of the pump (the so-called longitudinal vortex). In this case, the value ω_{fluid}/ω is an indicator of the TFP efficiency.

The fluid that rotates in the free passage of the TFP (free vortex) with velocity ω_{fluid} determines the pump head. Accordingly, the larger the value ω_{fluid} , the more efficient the pump is. There are both vortex and blade operating process in the TFP. In addition, the operating process of the TFP is similar to the operating process of a centrifugal pump fitted with open or semi-open impellers.

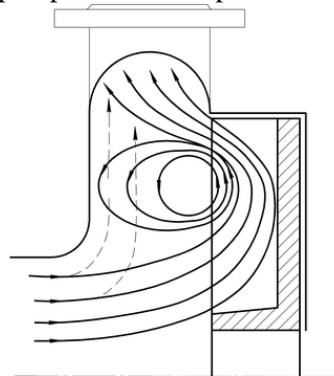

Figure 2. Flow pattern in torque flow pump of Turo type.

Improvement of the TFP within a large range of values n_s should be performed by designing these pumps implementing new principles of operation that could replace the TFP of Turo type but keep the corresponding functional performance of the latter.

One of the possible ways to improve the economic efficiency of the TFP of Turo type is to modify the pump or impeller design, extend the impeller into a free passage, increase the area of the pressure side of impeller blade or extended blades.

But, since TFPs of Turo type are vortex hydraulic machines the operation of which is characterized by the inevitable hydraulic losses generated by vortex formation, a more effective way to improve the efficiency of these pumps is to affect their operating process. Given that the mechanism of energy transfer in the TFP is caused by both blade and vortex operating process, that is, the fluid rotates in the free passage around the axis of the pump at an angular velocity ω_{fluid} , to improve the efficiency of the TFPs some design solutions, oriented to increase of ω_{fluid} , must be implemented. From the above it follows that the energy transfer due to the rotation of the fluid around the axis of the pump (free vortex) is more effective than that due to the presence of a longitudinal vortex. One of the design solutions contributing to the increase of ω_{fluid} may be the impeller with two extended blades according to [9] (Fig. 3 and 4).

2. Equation defining the relation of the head with the basic geometrical parameters of the pump (basic equation of the TFP)

The basic equation of the TFP with the impeller that has several extended blades (dependence of the head on the geometric dimensions of the hydraulic passage) is derived for the optimum performance of the pump (best efficiency point), based on the adopted scheme of the operating process (Fig. 5).

Pump head [4,10]:

$$H = \frac{\omega}{\rho g} \cdot \frac{1}{Q} \cdot \frac{\eta}{\eta_{MEX}} \cdot M_K, \quad (1)$$

where $M_{impeller}$ – moment with which the blades act on fluid;
 ω – impeller angular velocity;
 ρ – density;
 Q – pump capacity;
 η – pump efficiency;
 η_m – pump mechanical efficiency.

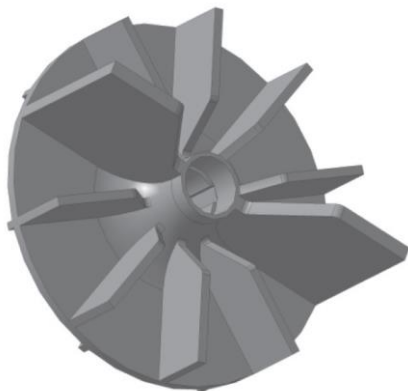

Figure 3. Experimental impeller.

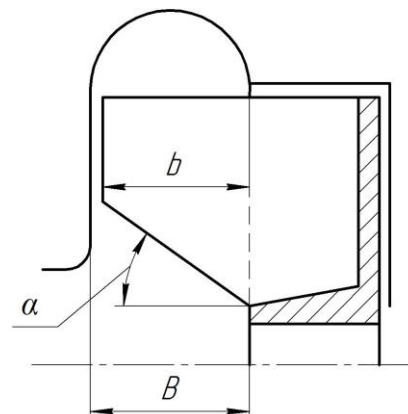

Figure 4. Impeller geometrical parameters.

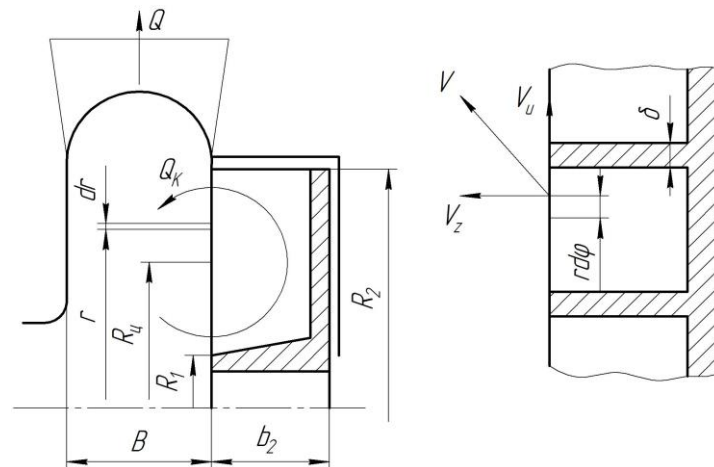

Figure 5. Calculation of fluid movement in TFP.

Let us write the momentum $M_{impeller}$ as the sum of the momenta acting on the impeller blades of a standard width (recessed impeller) M_1 and on the blades extended into free passage M_2 . Then the equation of the head is the following:

$$H = \frac{\omega}{\rho g} \cdot \frac{1}{Q} \cdot \frac{\eta}{\eta_{MEX}} \cdot (M_1 + M_2) = \frac{\omega}{\rho g} \cdot \frac{1}{Q} \cdot \frac{\eta}{\eta_{MEX}} \cdot M_1 + \frac{\omega}{\rho g} \cdot \frac{1}{Q} \cdot \frac{\eta}{\eta_{MEX}} \cdot M_2 \quad (2)$$

The first member of the equation is the impeller head generated by the blades recessed into the pump casing, and is determined by equation [8]:

$$H_1 = 2\pi \cdot \frac{\omega^2}{g} \cdot \frac{\eta}{\eta_{MEX}} \cdot F_1 \cdot F_2 \cdot D_2^2, \quad (3)$$

where D_2 – impeller outer diameter;
 F_1 – function that depends on the geometric dimensions of the impeller;
 F_2 – function that takes into account the effect of the longitudinal vortex intensity.

To determine the second member in the equation of the head, we take a calculation scheme that is built on a rotation with a constant frequency in a stationary medium of a flat radial plate.

Hydrodynamic force acting on the elementary plane dS

$$dF = \frac{\rho\omega^2 r^2}{2} dS. \quad (4)$$

On having summed up the area of the blades, extended in the free passage, we obtain the force acting on it

$$F = \int_S \frac{\rho\omega^2 r^2}{2} dS = \frac{\rho\omega^2}{2} \int_S r^2 dS = \frac{\rho\omega^2}{2} J_x, \quad (5)$$

where J_x – axial momentum of inertia of the blades extended into the free passage relative to the axis of rotation.

Given that the force F is applied in the center of gravity of the area of the blades extended into the free passage, we write an equation for the moment

$$M_2 = F \cdot r_{U.T.} = \frac{\rho \omega^2}{2} \cdot J_x \cdot r_{U.T.}, \quad (6)$$

where r_{cg} – the radius of the center of gravity of the area of blades extended into the free passage.

Considering the number of blades Z extended into the free passage, the head is calculated as follows

$$H = \frac{\omega^2}{g} \cdot \frac{\eta}{\eta_{MEX}} \left(2\pi \cdot F_1 \cdot F_2 \cdot D_2^2 + \frac{\omega}{2Q} \cdot J_x \cdot r_{U.T.} \cdot Z \right). \quad (7)$$

The resulting equation can be used to calculate the geometric parameters of the hydraulic passage of the TFPs of Turo type with the impeller, which has several blades extended into the free passage.

3. Analysis of the energy balance in TFP

Now consider the energy balance in the TFP with the experimental impeller. In the analysis of the energy balance [7] the following types of losses are distinguished:

- mechanical losses (friction losses in shaft seals N_{Lseal} , friction losses in bearings $N_{Lbearing}$, disc friction losses $N_{Ldiscfric}$)

- hydraulic losses (losses during the first stage of the energy transfer process $N_{1^{st} stage}$ - losses at the pump inlet and at the inlet to the impeller; losses during the second stage $N_{2^{nd} stage}$ - losses caused by eddy displacement losses in the free passage of the pump; losses in the hydraulic passage outlet N_{outlet}).

In the case of a combined operating process, the exchange of momentum between the impeller and fluid is performed due to both the longitudinal free vortex action in the free passage of the pump and the blade effect - similar to the operating process in centrifugal pumps. That is, the blades extended in the free passage of the TFP change its energy balance: losses in the second stage of the energy transfer process are divided into losses of the vortex operating process and losses of the blade operating process (Fig. 6). The blade effect is more perfect in terms of energy efficiency, since the hydraulic efficiency of the centrifugal pumps is 0.85-0.95, and in the vortex pumps the corresponding efficiency of the operating process is 0.60-0.63. Thus, the total efficiency of the pump increases, and the greater the ratio $\frac{N_{blade}}{N_{vortex}}$ the greater the efficiency is. Practically, the maximum achievable efficiency of such pump corresponds to the level of efficiency of centrifugal pumps with an open impeller.

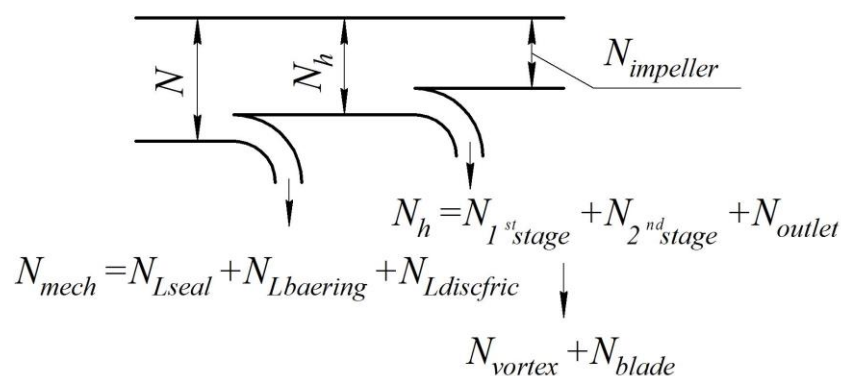

Figure 6. Balance of energy in TFP of Turo type with combined operating process.

4. Confirmation of results at a test rig

The assumptions made about the effect of the extended blades of the impeller on the performance of the TFP were verified experimentally at a test rig of the Department of Applied Fluid Mechanics of Sumy State University. The test program included efficiency and power input tests of AHIIIIC 50/16 pump with a standard impeller ($D_2=230$ mm, $z=10$, $b_2=30$ mm, $B=50$ mm) without two extended blades $b = 47$ mm. Figure 7 shows characteristic curves of the pump at zero $b=0$ with completely recessed impeller and maximum extended blades in the free passage $b=47$ mm.

According to the test results, the head at the design flow rate $Q = 50 \text{ m}^3/\text{h}$ at maximum extended blades is around 10% and the efficiency 4.5% greater compared to completely recessed impeller.

The increase in the parameters of the pump can be explained by the fact that the more impeller blades extend to the free passage the more circumferential component of the velocity ω_{fluid} is in the area where two flows mix together – the one that exits the impeller and another that circulates in the free passage. Also it creates an increase of the energy transmitted to the circulating flow and, as a consequence, the number of cycles of its rotation reduces in the free passage before entering the discharge nozzle. This, in turn, reduces hydraulic fluid friction losses in the casing and increases the pump head and efficiency. In addition, the portion of the blade operating process increases during energy transition in the TFP.

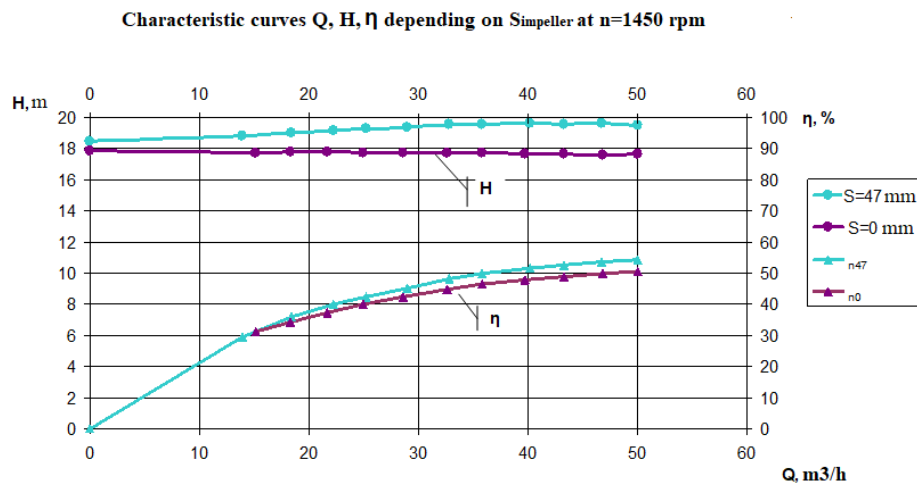

Figure 7. Characteristic curves of AHIIIIC 50/16 pump at $b=0$ mm (completely recessed impeller) and $b=47$ mm (impeller with maximum extended blades).

The obtained results are of practical interest. In the pump design with impeller, which has several extended blades, a combined (blade and vortex) operating process is implemented.

5. Conclusion

The mechanism of energy transfer in the TFP is caused by a combined operating process. Economic efficiency of the pump can be improved by increase of the portion of the blade operating process.

The TFP is a vortex hydraulic machine in which the ratio of the fluid velocity in the free passage to the impeller rotational speed ω_{fluid}/ω is an indicator of the TFP efficiency.

The study have shown that economic efficiency of the TFP of Turo type can be improved and its scope can be increased by modifying the design of the pump, namely the use of an impeller with extended blades.

The basic equation of the TFP, which determines the dependence of the head on the geometric dimensions of the hydraulic passage of the pump with an improved impeller, is obtained by analytical method, which allows us to clarify methodological recommendations for its designing.

Impeller blades that extend into the free passage change its energy balance.

Experimental studies have confirmed the feasibility of changing the geometry of the impeller (extended blades into a free pump passage) in the TFP of the Turo type, since the pump head increases by 10% and the efficiency by 4.5%.

The proposed solution has limitations when liquids with large solid inclusions are pumped [11].

References

- [1] Vortex pumps EGGER series T: <http://www.flowex.com.ua/index.php/vikhrevyye-nasosy-serii-t>
- [2] German V F 1984 *Creation and research of mass-flow torque flow pumps of increased economy: PhD dissertation* (Sumy: SumSU)
- [3] Yevtushenko A O 2013 *Development of the theory of the working process, the practice of designing and using dynamic pumps: monograph* (Sumy: SumSU)
- [4] German V F, Kovalev I A, Kotenko A I and Gusak A G 2013 *Torque flow pumps (second revised edition)* (Sumy: SumSU)
- [5] Kryshchuk I V 2015 *Advanced design of volute of torque flow pump with improved hydraulic performances: PhD dissertation* (Sumy: SumSU)
- [6] Kondus V Y 2018 *Improving energy efficiency and expanding the parametric range of free-vortex pumps by improving the working body: PhD dissertation* (Sumy: SumSU)
- [7] Panchenko V O 2019 *Improve the technical level of the torque flow pump by improving the geometry of the impeller: PhD dissertation* (Sumy: SumSU)
- [8] Gusak A G, Krishtop I V, German V F, Baga V N 2017 Increase of economy of torque flow pump with high specific speed *IOP Conf. Series: Materials Science and Engineering* **233** 012004
- [9] Panchenko V O, Yevtushenko A O, Solyanik V O, Morgal O S 2010 Torque flow pump *Pat. №56039 Ukraine, F04D7/00 u 201006394*
- [10] Panchenko V O 2018 The basic equation of a torque flow pump with a combined workflow *Scientific pages* **9** 39
- [11] Antoszewski B, Tarellyk V 2014 Laser texturing of sliding surfaces of bearings and pump seals *Applied Mechanics and Materials* **630** 301